

EA190V

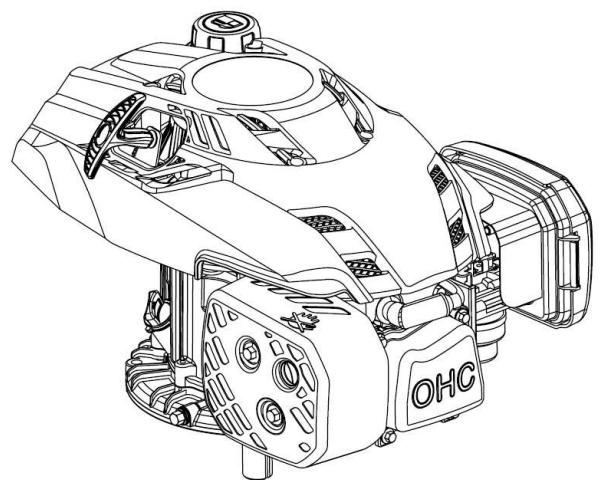

SERVICE MANUAL

This manual contains information on how to routine maintain and how to do troubleshooting.

Keep service manual handy, so you can refer to it at any time.

This service manual describes correct methods of maintaining this engine. As a result of person casualty and equipment damaged caused by the disregard for the rules, our company does not assume any responsibility.

NOTICE:

Copyright reserved, and no part of this publication may be reproduced without Fuji Heavy Industries Ltd's written permission.

Safety Messages

Your safety and the safety of others are very important. We have provided important safety messages in this manual and on the engine. Please read these messages carefully.

A safety message alerts you to potential hazards that could hurt you or others. Each safety message is preceded by a safety alert symbol  and one of three words: DANGER, WARNING, or CAUTION.

These mean:

 **DANGER** You **WILL** be **KILLED** or **SERIOUSLY HURT** if you don't follow instructions.

 **WARNING** You **CAN** be **KILLED** or **SERIOUSLY HURT** if you don't follow instructions.

 **CAUTION** You **CAN** be **HURT** if you don't follow instructions.

 **NOTICE** Your engine or other property could be damaged if you don't follow instructions.

I. PARTS DESCRIPTION.....	1
1-1 Part description.....	1
1-1-1 Feature.....	1
1-1-2 Model & serial number.....	1
1-2 Specification.....	2
1-3 Service limit.....	3
II. DIMENSION AND TORQUE.....	4
2-1 Engine dimension.....	4
2-1-1 Appearance dimension.....	4
2-1-2 Installation hole position.....	5
2-1-3 P.T.O dimension figure.....	5
2-2 Torque value.....	6
2-3 Standard torque value.....	7
2-4 Important bolt torque value.....	7
III. MAINTENANCE.....	8
3-1. Maintenance schedule.....	8
3-2 Change oil.....	9
3-3 AIR CLEANER.....	10
3-4 Fuel parts.....	10
3-4-1 Strainer clean.....	10
3-4-2 Fuel check.....	11
3-5 Spark Plug Service.....	12
3-6 Valve clearance adjustment.....	13
3-7 Governor adjusting.....	14
IV. DISASSEMBLING AND SERVICING.....	16
4-1 Troubleshooting.....	16
4-1-1 Starting difficult.....	16
4-1-2 Power lack.....	17
4-1-3 Speed unstable.....	18
4-1-4 Unable igniting.....	19
4-1-5 Engine overheat.....	19
4-1-6 Abnormal sound.....	20
4-1-7 Exhaust gas color abnormal.....	20
4-2 Preparation of servicing.....	21
4-2-1 Safety precautions.....	21
4-2-2 Special tools.....	21
4-3 Engine.....	22
4-3-1 Recoil starter /housing.....	22
4-3-2 Fuel tank.....	23
4-3-3 Ignition coil/flywheel.....	24
4-3-4 Muffler.....	26
4-3-5 Air cleaner.....	27
4-3-6 Carburetor.....	28
4-3-7 Throttle control.....	32
4-3-8 Cylinder head/valve train.....	33
4-3-9 Crankcase cover/governor gear.....	38
4-4-10 Crankshaft/piston/crankcase.....	39
4-5 Electric diagram.....	46

I. PARTS DESCRIPTION

1-1 Part description

1-1-1 Feature

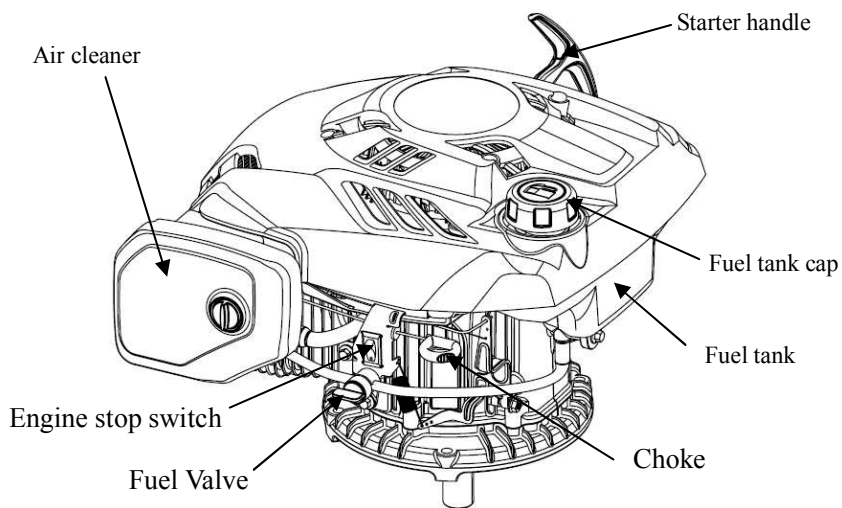
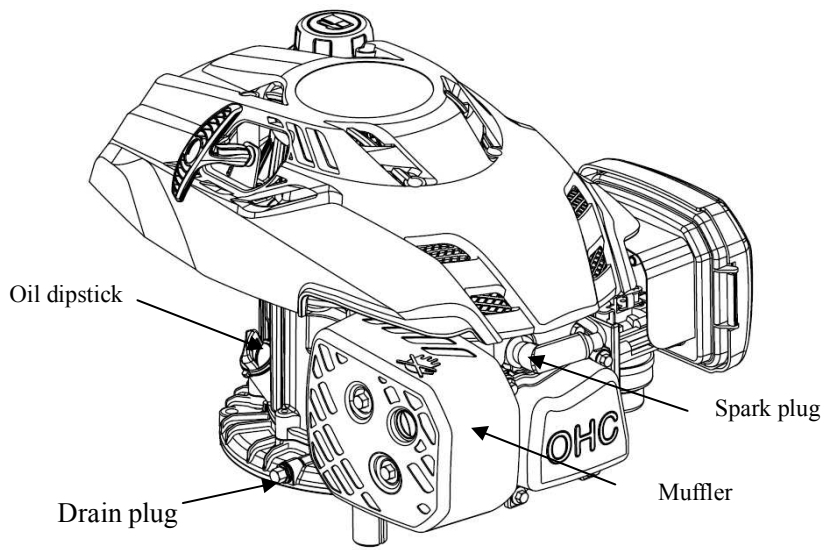

1-1-2 Model & serial number

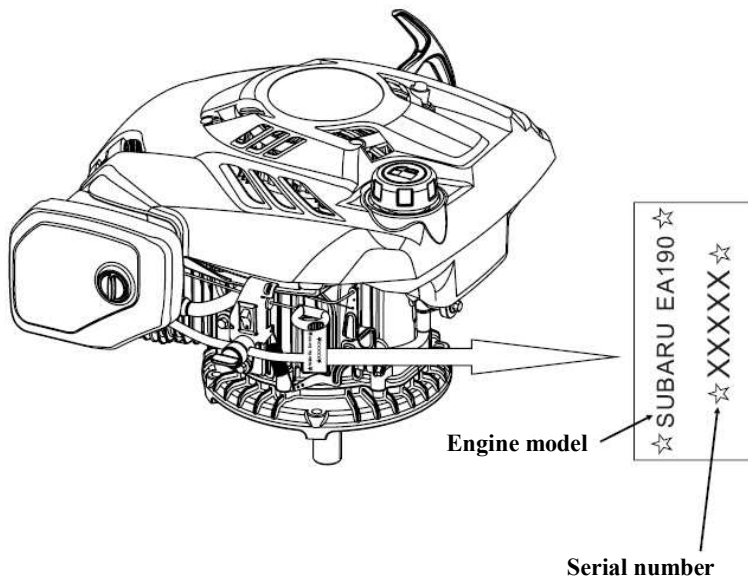

1-2 Specification

Specification	Model
	EA190
L×W×H(not including crankshaft output terminal)	425×360×290mm
Dry Weight	14kg (iron flywheel) or 13kg (aluminum flywheel)
Engine Type	Single cylinder vertical,4-stroke, (OHC)
Displacement	189ml
Bore × Stroke	68mm×52mm
Theoretical Maximum Power	3.72kW/3,600r/min
Recommended Using Power	3.5 kW/3,400r/min
Maximum Torque	11.2N·m /2,500r/min
Fuel Consumption	395g/Kw·h
Cooling System	Forced air
Ignition System	Capacitance discharge type
PTO Shaft Rotation	Counterclockwise view from P.T.O. side

1-3 Service limit

UNIT: mm

Parts	Item	Standard	Service limit		
Engine	Maximum speed (No load)	3800±100rpm	3650/4000-		
	Cylinder compression	1.15Mpa at 1200rpm	-		
Cylinder head	Sleeve I.D	68.00-68.02	68.160		
Cylinder head	Flatness	0-0.05	0.100		
Piston	Skirt O.D.	67.971-67.989	67.850		
	Piston – to cylinder clearance	0.011-0.049	0.120		
	Piston pin bore I.D.	16.006-16.012	16.450		
	Piston pin O.D	15.994-16.00	15.940		
	Piston pin-to-piston pin bore clearance	0.006-0.018	0.060		
Piston rings	Ring side clearance: first/ second	0.04~0.08/0.04~0.08	0.150		
	Ring width: first/second	2.60±0.10/2.80±0.10	2.300		
	Ring end gap: first/second	0.13~0.28/0.20~0.40	1.000		
Connecting rod	Small end I.D	16.005-16.021	16.090		
	Big end I.D	30.000-30.018	30.066		
	Big oil clearance	0.019-0.049	0.120		
	Big end side clearance	0.3-0.7	1.100		
Crankshaft	Crankshaft pin O.D	29.969-29.981	29.910		
Valve	Valve clearance	IN EX	0.10-0.15 0.15-0.20	0.4 0.4	
	Stem O.D	IN EX	5.440-5.455 5.430-5.445	5.310 5.300	
	Guide I.D	IN EX	5.500-5.520 5.500-5.520	5.590 5.590	
	Stem clearance	IN EX	0.045-0.080 0.055-0.090	0.100 0.120	
	Seat width		0.85	2.000	
	Spring free length		30.50	28.500	
	Camshaft	Cam height	IN EX	23.98 27.88	23.730 27.630
		Journal I.D		9.00-9.04	9.090
Camshaft I.D.			9.00-9.04	9.19	
Spark plug	Gap	0.6-0.7	-		
Ignition coil	Resistance	Primary coil Secondary coil	0.8-1.0 Ω 5.9-7.2 kΩ	- -	
	Air gap	(at flywheel)	0.35~0.45mm	-	

II. DIMENSION AND TORQUE

2-1 Engine dimension

2-1-1 Appearance dimension

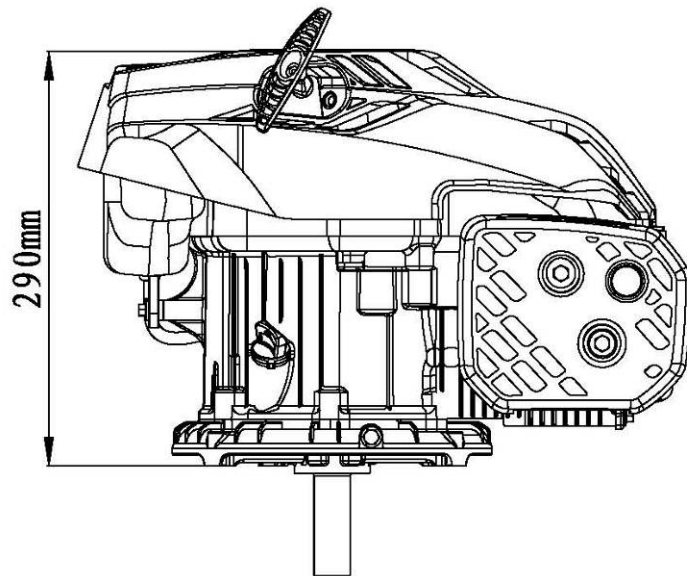
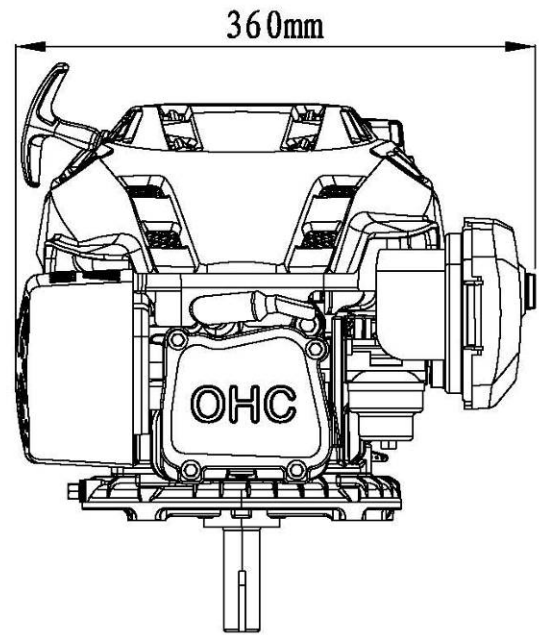
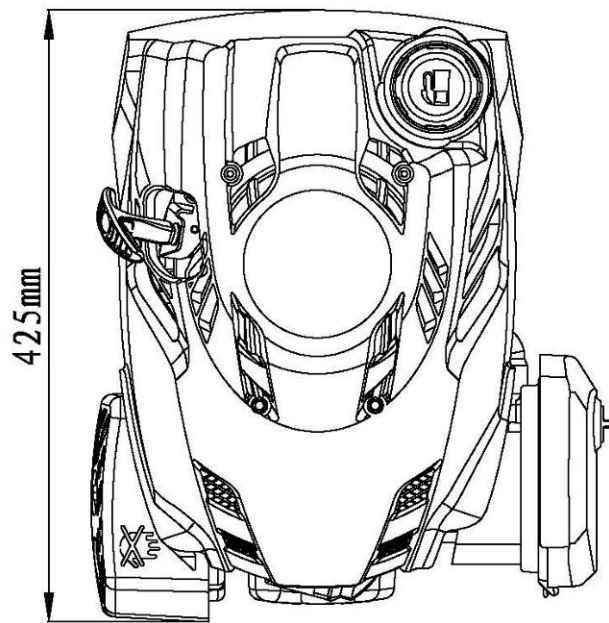

2-1-2 Installation hole position

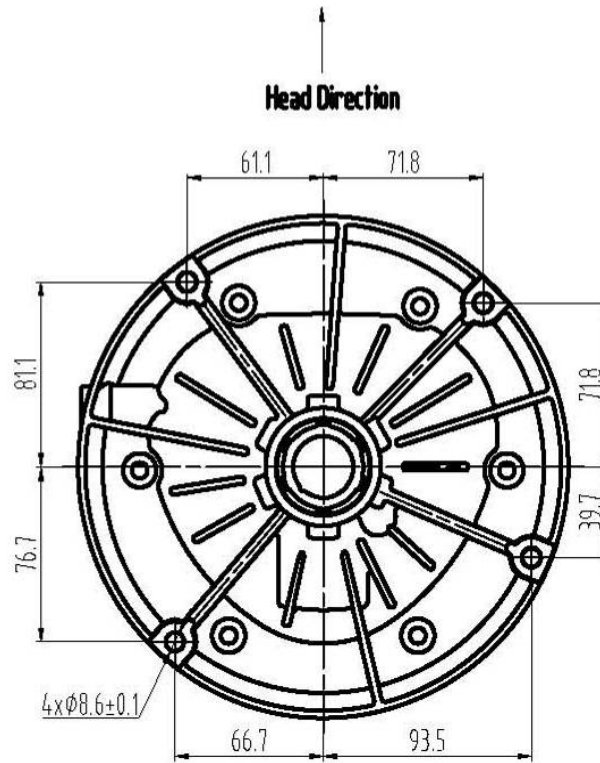

2-1-3 P.T.O dimension figure

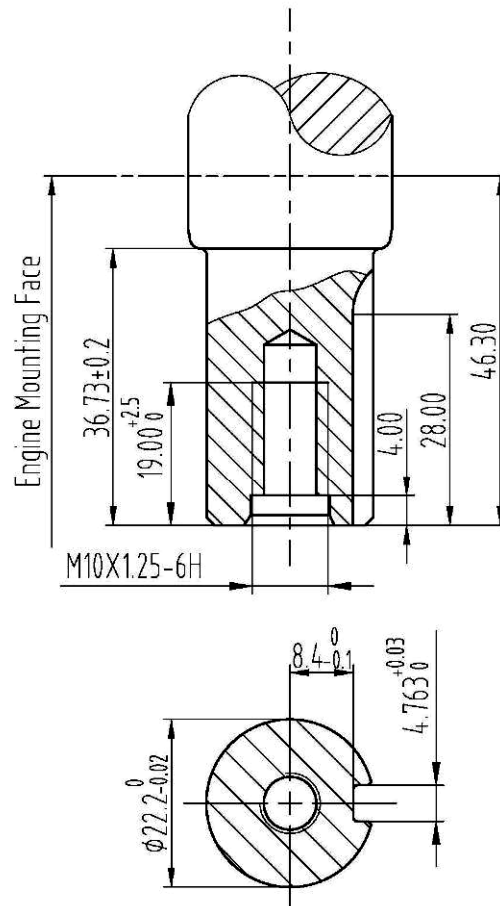

2-2 Torque value

No.	Item	Specification	Performance class	Torque value (N·m)
1	Cylinder head	M8×65	10.9	28±2
2	Crankcase cover	M6×30	8.8	10±1
3	Oil drain plug	M10×15	8.8	22±2
4	Connecting rod	M6×35	10.9	13±1
5	Valve locking nut	M5	8	8±1
6	Governor gear	M6×16	8.8	10±2
7	Flywheel	M14 (iron flywheel)	8	78±4
		M14 (aluminum flywheel)	8	68±4
8	Spark plug	M14×1.25	8.8	28±2
9	Valve cover	M6×12	8.8	10±2
		M6×80	8.8	
10	Breath groove covering plate	M6×12	8.8	10±2
11	Brake	M6×12	8.8	10±2
		M6×20	8.8	
12	Ignition coil	M6×20	8.8	10±2
		M6×68	8.8	
13	Stud supporting bolt	M6×83	8.8	10±2
14	Lower shell	M6×16	8.8	10±2
15	Muffler stud	M8×109	8.8	25±2
16	Muffler nut	M8	8	25±2
17	Air cleaner	M6	8	8±2
18	Throttle control	M6×12	8.8	10±2
19	Governor support lock nut	M6	8	7±1
20	Recoil starter	M6	8	8±2
21	Fuel tank	M6×25	8.8	8±2
		M6	8	8±2
22	Engine housing	M5×20	8.8	6±2

Notice: For unspecified bolt, screw and nut, refer to the standard torque value

2-3 Standard torque value

Fasteners	Thread dia.(mm)	Torque value (N·m)
Bolt and nut	5mm bolt, nut	4.5-6
	6mm bolt, nut	8-12
	8mm bolt, nut	18-25
	10mm bolt, nut	29-34
	12mm bolt, nut	49-59
	4mm screw	1.5-2.6
	5mm screw	3.5-5
	6mm screw	7-11
	5mm flange bolt	3.6-6.9
	6mm screw	7-11
	5mm flange bolt	3.6-6.9
	6mm flange bolt	10-14
	8mm flange bolt	20-26
	10mm flange bolt	35-45

2-4 Important bolt torque value

Item	Thread dia.(mm)	Torque value	
		N·m	Kg·m
Connecting rod bolt	M6×1.0	13	1.3
Cylinder head bolt	M8×1.5	28	2.8
Flywheel nut	M14×1.5	64	6.4
Crankcase cover bolt	M6×1.0	10	1.0
Valve locking nut	M5×0.5	8	0.8

III. MAINTENANCE

3-1. Maintenance schedule

Good maintenance is essential for safe, economical, and trouble-free operation. It will also help reduce air pollution.

⚠ WARNING Exhaust gas contains poisonous carbon monoxide. Shut off the engine before performing any maintenance. If the engine must be run, make sure the area is well ventilated.

Periodic maintenance and adjustment is necessary to keep the engine in good operating condition. Perform the service and inspection at the intervals shown in the Maintenance schedule below:

Maintenance schedule

Item		Frequency	Each time	First month or 20 hrs	Each season or 50 hrs	Every 6 months or 100 hrs	Each year or 300 hrs
Engine oil	Oil level check		√				
	Replace			√		√	
Air cleaner	Check		√				
	Clean –replace				√		
Spark plug	Check, clean					√	
	Adjust					√	Replace
Fuel strainer	Clean					√	
Valve clearance	Check-adjust						√*
Cylinder head	Clean						√*
Fuel tank	Replace	Every 3 years					
Cylinder head/piston	Clean carbon deposit	Each 150 hours*					

“*” This items should be serviced by company authorized dealer, unless you have the proper tools and mechanically proficient.

NOTICE

Service more frequently when used in dusty areas.

3-2 Change oil

·change oil

NOTICE:

Drain the engine oil rapidly and completely out when the engine is hot.

- (1) Remove the drain plug and washer and tilt the engine to drain engine oil thoroughly.
- (2) Reinstall the drain plug and washer into securely by hand.
- (3) Tighten the oil drain plug, EA190 torque value: 20-24N.m.
- (4) Remove the dipstick and wipe up oil.
- (5) Refill the recommended clean oil (EA190 engine capacity: 0.6L) and check oil level.

Lay the engine and place it on the level ground when checking.

Check as following:

- a). Insert the dipstick into the filling hole without screwing down and check the oil level.
- b). If the oil level is too low, add the recommended engine oil up to the oil upper limit.
- c). Reinstall the dipstick and screw down.

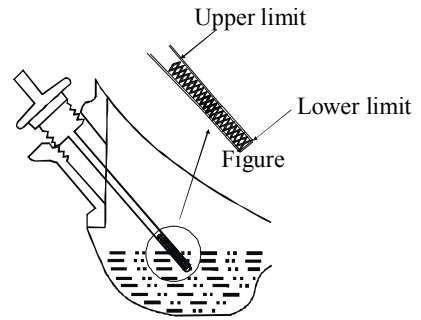
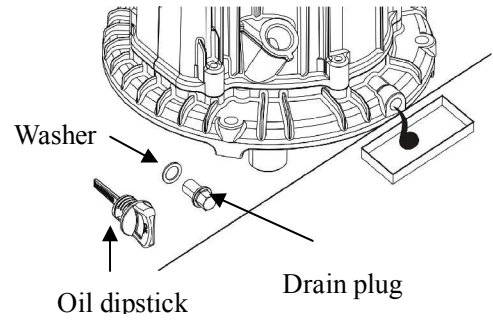

NOTICE:

Use 4-stroke engine oil, API service classification SE class or equivalent. Always check the API service label on the oil container to assure it includes the letters SE or equivalent.

SAE10W-30 is recommended for general use. Other

viscosities shown in the chart may be used when the average temperature in your area is within the indicated range. Recommend user to use SF class or equivalent.

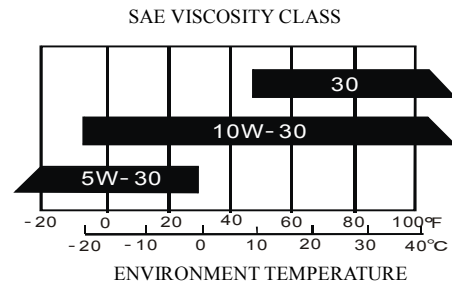

WARNING: Engine oil is a major factor affecting engine performance and service life. Additive-free and 2-stroke engine oil will damage the engine.

NOTICE: For environment protecting, please properly handle with the used oil. Running with insufficient engine oil may damage the engine severely and it will not be covered the range of the warranty.

CAUTION

Used engine oil may cause skin cancer if repeatedly left in contact with the skin for prolonged periods. Although this is unlikely unless you handle used oil on a daily basis, it is still advisable to thoroughly wash your hands with soap and water as soon as possible after handling used oil.

3-3 AIR CLEANER

NOTICE: A dirty air cleaner will restrict air flow to the carburetor. To prevent carburetor malfunction, clean the air cleaner each 50 hours (or three months) and service the air cleaner regularly. Service more frequently when operating the engine in extremely dusty areas.

⚠ WARNING Using gasoline or flammable solvent to clean the filter element can cause a fire or explosion.
Use only soapy water or nonflammable solvent.

Never run the engine without the air cleaner. Rapid engine wear will result.

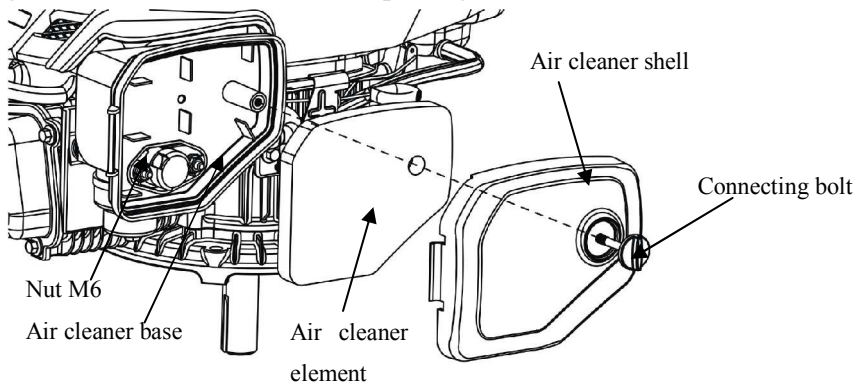

- ① Screw off the connecting bolt and remove the air cleaner shell.
- ② Remove foam element or paper element. Be careful to prevent dirt and debris from falling into the air cleaner base when opening,
- ③ Clean the element

Foam element: Clean the foam with detergent, and then blow it dry with compressed air or squeeze it dry. Dip the element in clean oil, and then forcefully squeeze it dry and install it back.

Paper element: Tap the element lightly several times on hard surface to remove excess dirt or blow compressed air lightly from the inside out. If dirty, replace in time.

CAUTION: Foam element containing too much oil will jam the foam element holes.

- ④ Check, clean or replace damaged air cleaner parts.
- ⑤ Reassemble the air cleaner element into the shell, install foam element or paper element back, cover the shell on and screw in the connecting bolt.

3-4 Fuel parts

⚠ WARNING Don't smoke or use flame fires near the flammable solvent.

3-4-1 Strainer clean

- (1) Drain the fuel into the container.
- (2) Loosen the clip, remove fuel tube and pull the strainer out.
- (3) Check the strainer for damaged and clean the strainer in the container.
- (4) After cleaning, reinsert the strainer in the fuel tank, connect fuel tube and tighten the clips.

NOTICE:

Check all connecting position for leaking.

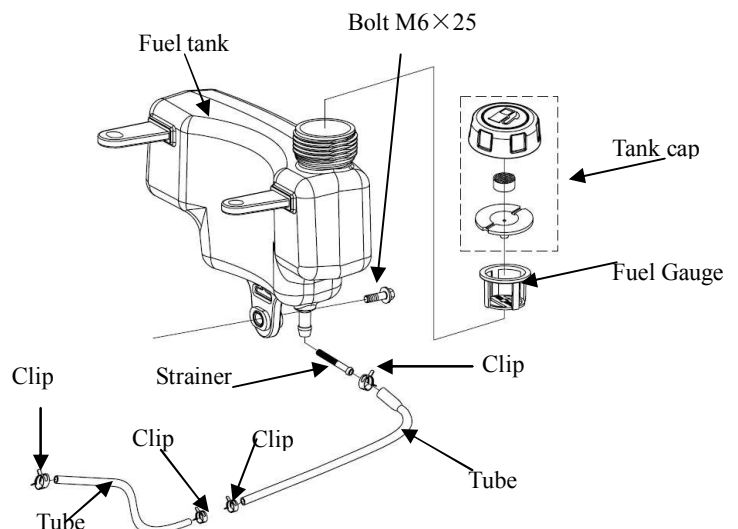

3-4-2 Fuel check

1. Remove the fuel tank cap and check fuel level.
2. If the level is too low, refuel the tank. Please don't refuel over the fuel gauge.

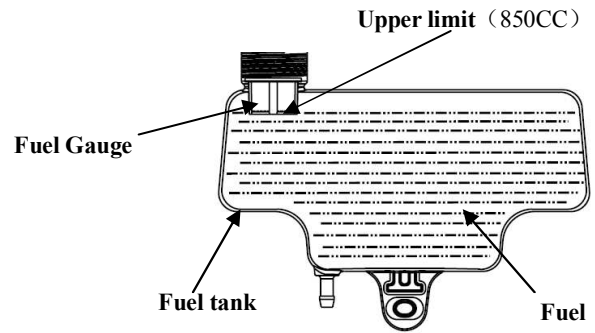

WARNING:

1. Gasoline is extremely flammable and is explosive under certain conditions.
2. Refueling in a well-ventilation area with the engine stopped. Do not smoke or allow flames or sparks in the area where gasoline is stored or where the fuel tank is refueled.
3. Do not overfill the fuel tank (The fuel will not exceed the fuel gauge). After refueling, make sure the fuel tank cap is set back securely.
4. Be careful not to spill fuel when refueling. Spilled fuel or fuel vapor may ignite. If any fuel is spilled, make sure the area is dry before starting the engine.
5. Avoid repeated or prolonged contact with skin or breathing of fuel vapor.
6. Keep out of reach of children.

RVC 190 fuel tank capacity: 1.0L

Only use unleaded gasoline and recommend gasoline grade 90[#] over.

Unleaded gasoline can reduce gasoline engine carbon deposit and prolong the exhaust system service life.

Never use contaminated gasoline or mixed gasoline with oil. Don't allow the dust, foreign matter or water entering into fuel tank.

CAUTION:

Fuel may damage the oil paint and plastic. Be careful not to spill fuel when refueling. Any damage due to fuel spilling is not within valid warranty.

If "knocking" or "spark exploding" sound occur at a steady speed under normal load, change grade of gasoline; if such phenomena still happen, consult your dealer for help, otherwise the engine may be damaged.

CAUTION:

When the engine is running, continuously "knocking" or "spark exploding" sound occurring will damage engine.

"Knocking" or "spark exploding" sound from misusing will not be within the valid warranty.

3-5 Spark Plug Service

- (1) Remove the spark plug cap. Clear away dirt around the spark plug base;
- (2) Use the plug wrench to remove the spark plug;
- (3) Visually inspect the spark plug, if the insulator is cracked, replace with new the spark plug, if deposit around the electrode, remove carbon or other deposits with a stiff wire brush;
- (4) Measure the spark plug clearance with a feeler. The clearance should be 0.6~0.7mm.If need adjusting, lightly tap (for gap too big) or pry up with flat screwdriver (for gap too small) electrode.
- (5) Check the spark plug washer if it is in good condition.
- (6) Install the spark plug on and screw down it with plug wrench, compress the plug washer. Cover the spark plug cap on.

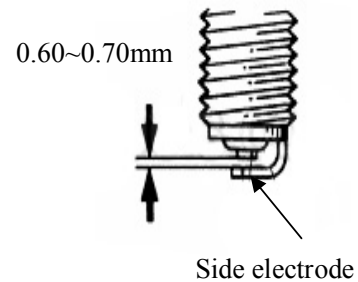
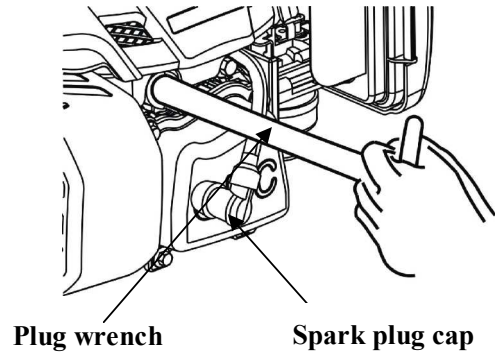

NOTICE:

To avoid cross-threading, first, screw in spark plug by hand, then tighten with a spark plug wrench to compress the gasket.

If a new spark plug is used, more twist 1/2 turns after compressing the gasket.

If reinstall the used spark plug, just more twist 1/8-1/4 turns.

Spark plug torque value: $22 \pm 2 \text{N} \cdot \text{m}$

The spark plug must be tightened securely, or it may become very hot to damage the engine.

When replaced, please pay attention to model of the spark plug to avoid damaging the engine or using recommended spark plug or the equivalent. Incorrect heat range of the spark plug may damage the engine

- EA190 recommended spark plug model: NGK——BPR7HS
CHAMPION——RL87YC
TORCH——E7RTC

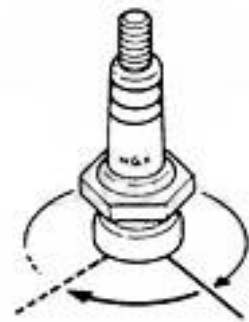

3-6 Valve clearance adjustment

Keep the clearance between engine valve rod end and driving parts for avoiding heat expanding and cold shrinking to effect engine performance. If the valve clearance is too big, it can result in exhausting unsmooth, effecting engine performance and increasing engine noise (valve abnormal); if the valve clearance is too small, the valve will close untight to make the engine operating abnormal. After operating one year or 300hrs, check and adjust the valve.

(1) Dismount the spark plug cap, spark plug, cylinder head cover bolt, cylinder head cover and gasket in order.

CAUTION: After the cylinder head cover is removed, engine oil may flow. Be sure to wipe up any flowed oil.

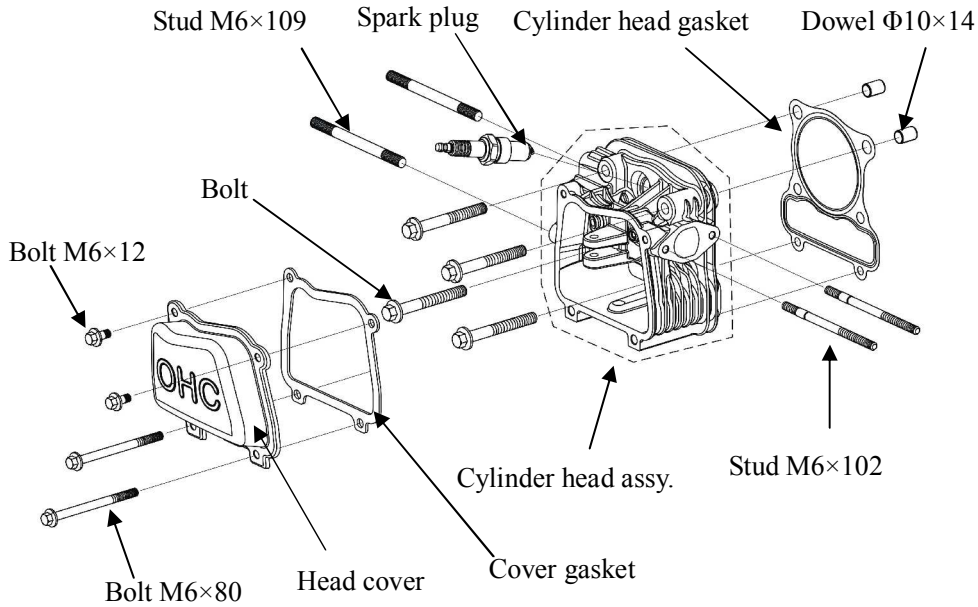

(2) Lightly pull the starting rope and set the piston at top dead center of the compression stroke (insert screwdriver into the hole of the spark plug to check the height of piston.)

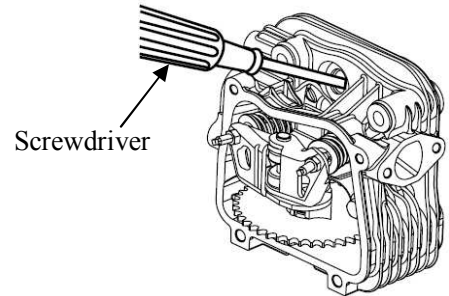

(3) Measure the valve clearance: Insert the feeler into the clearance to measure clearance.

Valve clearance	IN: 0.10-0.15mm EX: 0.15-0.20mm
-----------------	------------------------------------

- Adjust if the valve clearance is out of the service limit.

CAUTION:

Measure the valve clearance in the cold engine state.

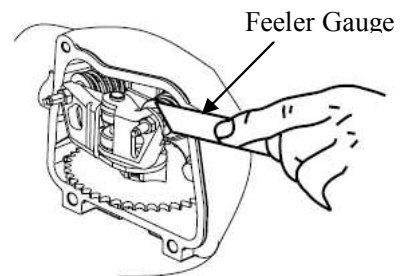

(4) If adjustment is necessary, proceed as follows:

- Hold valve adjusting bolt with tongs and loosen the valve lock nut.
- Turn valve adjusting bolt to obtain the specified clearance.
- Fix the valve adjusting bolt with tongs, and then fix the valve lock nut with spanner.

- d. Recheck valve clearance after tightening the valve lock nut—torque value: $8 \pm 1 \text{N.m}$.
- e. Set the new gasket aligning the projection of the new gaskets with the projection of the cylinder head.
- f. Install the valve cover and tighten the four bolts to the specified torque—bolt torque value: $10 \pm 2 \text{N.m}$.

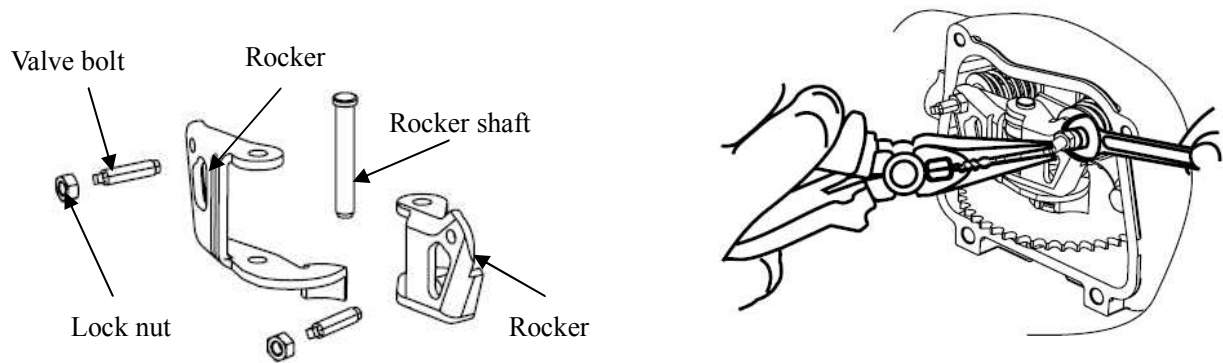

Valve bolt—screw in: valve clearance becomes smaller

Valve bolt—screw out: valve clearance becomes bigger

CAUTION:

Clearance too big: Intake and exhaust valve opening delay will shorten the intake and exhaust time, lower the opening height of the valve and change normal distributing phase to result in power lowering from the intake lack and exhaust incomplete. Furthermore, it will also make valve train parts knock increasingly and wear quickly.

Clearance too small: After running, engine parts will be heated to expand and push the valve open, making the engine closing not tight and result in leaking, power lowering, serious carbon deposit or burn on the valve surface, even valve impacting the piston.

3-7 Governor adjusting

• Governor adjusting:

- (1) Dismount the air cleaner.
- (2) Loosen the nut M6. Be sure that the carburetor throttle valve is fully open.
- (3) Rotate the governor arm shaft fully to the right (governor fully open position) to bottom by pressing governor support, and retighten the nut—torque value: $7 \pm 1 \text{N.m}$.
- (4) Check to see that the governor support and throttle valve move freely.
- (5) Check the maximum engine speed.

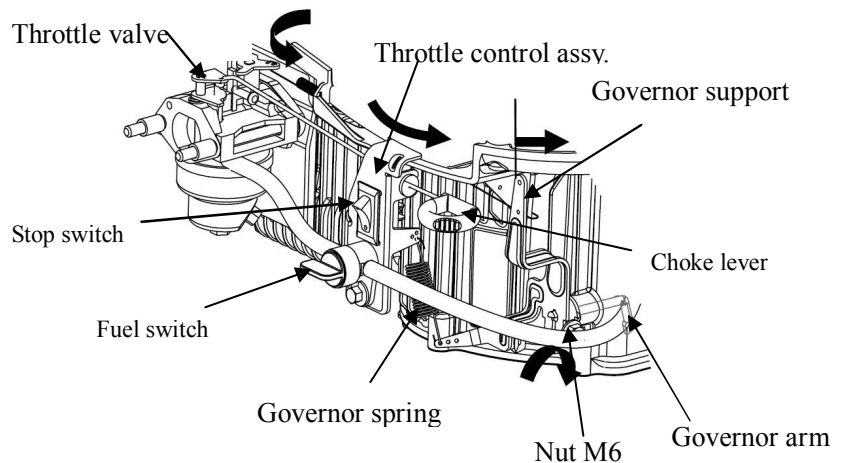

Adjusting speed:

Don't adjust the speed because it is fixed. If necessary, please send it to the authorized dealer for adjusting. If the user has a proper tools and repairing capacity, only permit the following operation:

- (1) Start the engine and allow it to warm up to normal operating temperature.
- (2) If the maximum speed is not conformed to specified value, adjust throttle control and hole position of the support by adjusting governor spring.

EA190 engine maximum speed: 3800 ± 100 rpm.

WARNING:

The engine has adjusted to specified speed when manufactured in the factory, if the wrong adjusted from the user to cause the performance of the engine, it is not covered the warranty of our company.

IV. DISASSEMBLING AND SERVICING

4-1 Troubleshooting

4-1-1 Starting difficult

TROUBLE			CAUSE		REMEDY
Normal cylinder compression	Normal spark plug spark	Something wrong with the fuel system.	Fuel supply is not smooth or no fuel supply.	There is no enough fuel in fuel tank and fuel cock is closed.	Fill fuel, open fuel cock.
				Air vent in the fuel filler cap is clogged	Dredge air vent.
				Improper or clogged carburetor main fuel channel.	Readjust or clean, blow to get through.
				Carburetor float needle valve is not closed properly or start hole is clogged.	Dismantle needle valve and repair, clean, blow to get through.
				Carburetor float is damaged or sticking.	Repair float
			Fuel supply is normal.	Fuel is too filthy or deteriorated	Replace
				There is water in fuel.	Replace
				Too much fuel in cylinder.	Drain extra fuel, dry up spark plug electrodes.
	Wrong fuel brand	Select proper fuel brand corresponding with the requirements.			
	Normal fuel supply system.	Normal high-tension line spark.	Spark plug is in bad conditions	Too much carbon deposit and dirt around electrodes.	Clear away.
				Electrodes are burn damaged seriously or insulators damaged.	Replace spark plug.
				Improper electrodes gap.	Adjust to proper value.
		High-tension line no spark	Normal spark plug	High-tension line is damaged.	Replace
				Ignition coil is damaged.	Replace
Magneto loses magnetism.				Replace	
Abnormal gap between the ignition coil and flywheel.				Adjust gap	
TROUBLE			CAUSE	REMEDY	
Abnormal cylinder compression	Normal fuel supply system	Normal ignition system	Piston ring is worn to or even over its wear limit	Replace	
			Piston ring is broken.	Replace	
			Piston ring is sticking.	Clear up carbon deposits	
			Spark plug is not tightened or without a gasket.	Tighten with a gasket in.	
			Air leakage between cylinder block and cylinder head.	Check cylinder gasket, and the flatness of the surface by which cylinder block contacting with cylinder head.	
				Tighten cylinder head bolts in stipulated order to stipulated torque.	
			Air leakage in the valves	Check, clearance and tightness, repair if necessary.	

● Spark plug testing

▲ WARNING

· Make sure there is no spilled fuel outside the engine and that the spark plug isn't dipped with fuel.

· To prevent fire, keep sparks far away from the spark plug mounting hole.

· When testing the spark plug, never hold the high tension line of the spark plug and spark plug cap with wet hand.

· If having fuel cock, turn the fuel cock to "OFF" position, (if no fuel cock, first drain the gasoline of the fuel tank, then, drain the gasoline of the carburetor)

· Remove the spark plug and spark plug cap.

· Install the spark plug cap

· Turn the engine stop switch to " | " or "STOP" position.

· Pass negative pole (thread) of the spark plug through cylinder cover to connect grounding and pull the starter handle to observe the spark

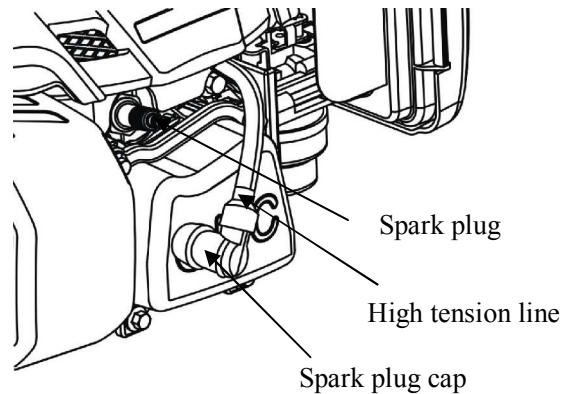

4-1-2 Power lack

TROUBLE	CAUSE		REMEDY
When increasing throttle, speed increase slow or even decrease and stop running	Ignition system Fuel supply system	Air in fuel line or fuel line clogged	Exhaust air or dredge fuel line
		Carburetor main fuel channel is not adjusted properly	Readjust
		In carburetor, needle valve hole and main fuel channel clogged.	Clean and blow to get through
		Fuel cock is clogged up.	Clean, replace damaged part
		Too much carbon fouling in muffler and exhaust pipe.	Clear away
		Too much carbon deposit in combusting chamber.	Clear away
		Air cleaner is clogged up.	Clean air cleaner filter element
		Intake pipe is leaking	Repair or replace
	Poor compression	Intake pipe is leaking	Repair or replace
		Piston or cylinder or piston ring is worn	Replace the worn parts
		Air leakage from the surface by which cylinder block contacting with cylinder head.	Replace cylinder gasket
		Too big or too small valve clearance.	Readjust

Cylinder pressure check

- Drain the gasoline in the fuel tank into the container.
- Drain the gasoline by loosening the fuel drain bolt of the carburetor
- Remove the spark plug cap and spark plug and install the cylinder pressure meter.
- Forcibly pull the recoil starter several times and measure compression force (Cylinder pressure: 0.2Mpa at 500rpm)

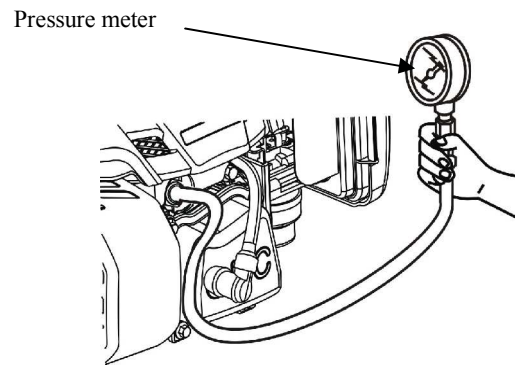

4-1-3 Speed unstable

TROUBLE	CAUSE	REMEDY
Knocking sound	Piston, cylinder or piston ring is worn excessively.	Replace the worn parts
	Piston pin and piston pin hole are worn excessively.	Replace piston or piston pin
	Connecting rod small head is worn excessively.	Replace tie rod
	Bearing for crankshaft main shaft is worn.	Replace roller bearing
Abnormal combustion	Engine is too hot	Better ventilation
	Too much carbon deposit in combustion chamber	Clear away
	Improper gasoline brand or low gasoline quality	Replace with qualified gasoline
Spark lacking	There is water in float chamber	Clean
	improper spark plug electrodes clearance	Adjust
	Something wrong with ignition coil, and so on	Check and replace damaged parts

4-1-4 Unable igniting

TROUBLE	CAUSE		REMEDY
Unable igniting	Fuel supply system	Fuel is finished	Refill fuel
		Carburetor is clogged	Check fuel line and dredge
		Float is leaking	Repair
		Needle valve is stucked	Dismantle float chamber and clean or replace needle valve.
	Ignition system	Spark plug is punctured, or short-circuited by carbon deposit	Replace spark plug
		Side electrode of spark plug is dropped out	Replace spark plug
		High-tension wire is dropped out	Weld on
		Ignition coil is punctured or short-circuited	Replace ignition coil
		Stop wire is located on engine body	Find out meeting and insulate
	The other	Cylinder is seriously scored and valve dropped out	Repair or replace damaged parts

4-1-5 Engine overheat

TROUBLE	CAUSE	REMEDY
Gasoline engine overheat	Abnormal oil volume or inferior oil	Check the oil level and quality
	Exhaust pipe blocked up	Clean exhaust pipe
	Shroud leaking	Repair damaged part
	Cooling fins blocked by foreign matter	Clear cooling fins
	Cooling fan is loosen and misfunctioned	Reinstall well
	Connection rod deformation to make piston and cylinder bushing side wear	Replace connection rod
	Cylinder or piston or piston ring is worn	Replace the worn parts
	Improper adjustment of engine governor to cause high speed.	Readjust engine governor
	Crankshaft main bearing burnt out	Replace main bearing

4-1-6 Abnormal sound

TROUBLE	CAUSE	REMEDY
Beating sound	Piston, piston ring or cylinder is worn	Replace the worn part
	Connection rod or piston pin and piston pin hole are worn	Replace the worn part
	Crankshaft main neck is worn	Replace bearing
	Piston ring is broken	Replace piston ring
Metal beating sound when abnormal combustion occurs	Too much carbon deposit in combusting chamber	Clear away carbon deposit
	Too small electrode clearance of spark plug	Adjust electrode clearance properly
	Engine fuel is too much	Check relative parts such as carburetor
The other	Improper fuel brand	Replace fuel
	Engine is overheat	Find a cause and eliminate it
	Improper valve clearance	Readjust valve clearance properly
	Fly wheel is not connected with crankshaft tightly	Connect tightly

4-1-7 Exhaust gas color abnormal

TROUBLE	CAUSE	REMEDY
Black smoke or blue thick smoke	Piston, cylinder or piston ring is worn excessively.	Replace the worn parts
	Too much carbon deposit in combustion chamber	Clear away
	Improper gasoline brand or low gasoline quality	Replace with qualified gasoline
	Air cleaner is clogged up.	Clean air cleaner filter element

4-2 Preparation of servicing

4-2-1 Safety precautions

WARNING:

Indicate a possibility of invalid warranty and personal or equipment damage if instructions are not followed.

Please pay special attention to the following:

1. Strictly set the engine according to the regulated power on the nameplate. Do not overload, overrun the engine or run it with low load and at low speed in a long time.
2. Use regulated brand of fuel. The fuel should be fully deposited and filtrated before use. Keep clean the fuel filler, change the oil periodically.
3. Periodically check the installation, connection and the degree of tightness of the fixed bolt. Tighten it if necessary.
4. Periodically clean the element of the air cleaner, change it when necessary.
5. The engine is air-cooled, so clean the cooling piece, wind guide cover and fan in time in order to make the engine cool normally.
6. The operator should be familiar with the working principle and structure of the gasoline engine, knowing how to make an emergent stop and the operation of all controlling parts. Any one without training is forbidden to operate the engine. Keep periodical maintenance. Solve problems in time. Do not run the engine in spite of malfunction.
7. Running the engine in a well-ventilated place, keep it at least one meter away from building walls or other equipments, keep away from inflammables such as gasoline, matches and so on to avoid possibility of fire.
8. Refuel in a well-ventilated area with the engine stopped, and in places refueling or storing gasoline, no smoking and any flames or sparks.
9. Refuel the fuel tank not too full so as to avoid fuel's spilling out. If there is spilled fuel around, be sure to clean it thoroughly before starting.
10. Do not run the engine in airtight or ill-ventilated places.
11. The exhaust muffler is very hot during running the engine even after the engine stops. Never touch it, or you may get burns. Transport or store the engine with it cooling down entirely.
12. Safe warning label:
Please carefully read warning label before operating. Our company will not assume any responsibility for person casualty, or equipment damaged caused by disregarding this warning label.

4-2-2 Special tools

Tool name	Application-note
1. Retainer assembler	Assembling ball bearing
2. Assembler handle	Installing handle and bearing
3. Inner retainer assembler	Assembling ball bearing and time.
4. Diamond lap 45 ⁰	Rectifying valve seat surface.
5. Diamond lap 32 ⁰	Rectifying valve seat surface.
6. Flywheel driver	Dismounting flywheel
7. Bearing extractor	Dismounting flywheel

4-3 Engine

4-3-1 Recoil starter /housing

Disassembly:

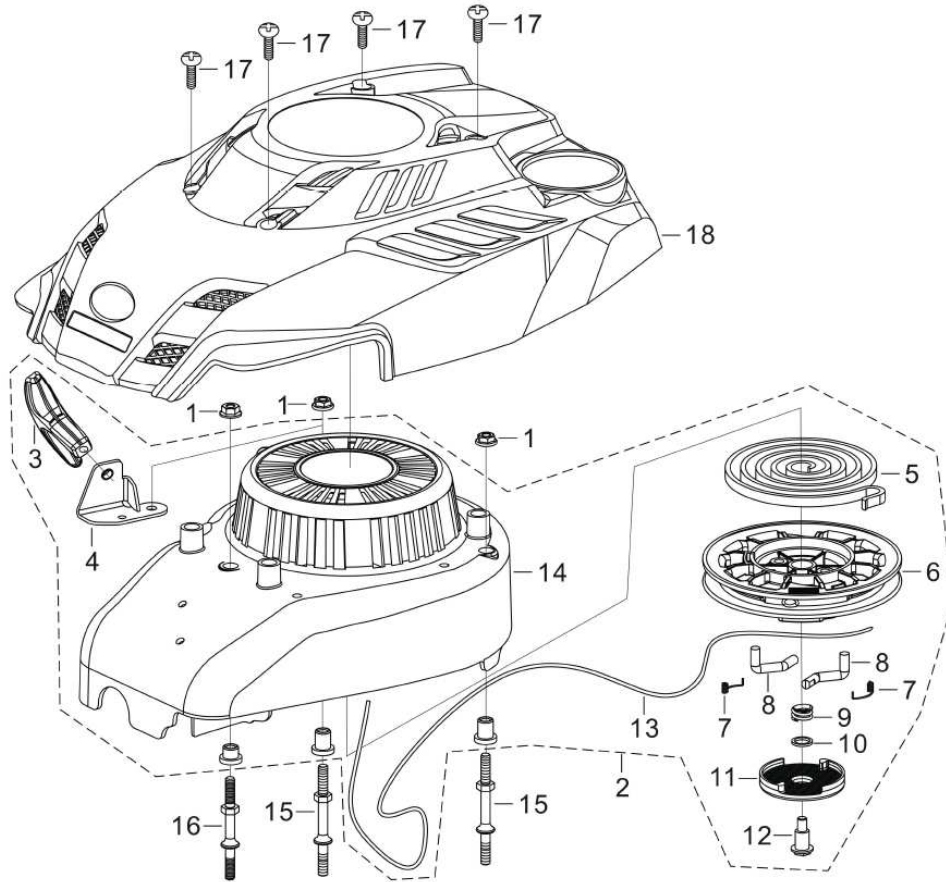

Ser. No.	Description	Ser. No.	Description	Ser. No.	Description
1	Hex. Flange nut M6	7	Return spring	13	Starter rope
2	Recoil starter	8	Driving pawl	14	Starter housing
3	Starting rope grip	9	Compression spring	15	Stud M6X83
4	Rope guide assy.	10	Washer	16	Stud M6X68
5	Starter coil spring	11	Drive guide	17	Philips screw assy. M5×20
6	Rope coil tray	12	Bolt	18	Shroud

NOTICE:

Wear gloves during disassembly, and take care not to allow the return spring to come out.

When assembling, first check starter rope for damaged or broken, then assemble it.

4-3-2 Fuel tank

● Disassembly/reassembly

The fuel tank does not require general maintenance, but, sometimes the dusts and vapor will trouble the fuel system, so that, periodically washing it with lubrication oil and gasoline is required.

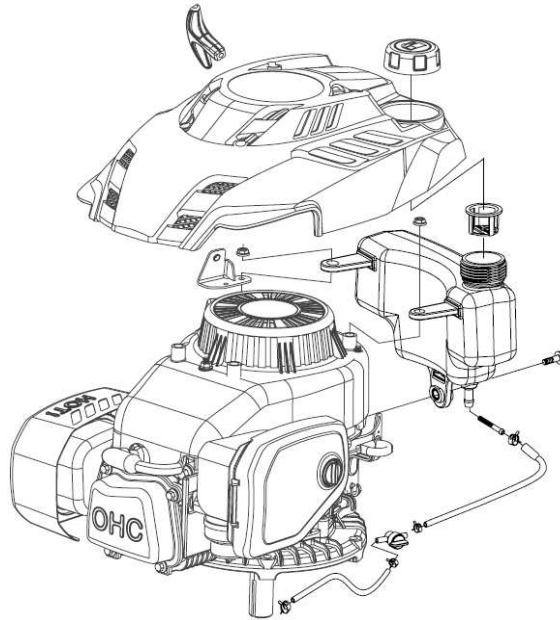

WARNING:

Don't smoke or use fire near the flammable solvent.

● Clean/installation:

- Check the fuel tube for damage or leak.
- Drain out the fuel into the proper container.
- Remove screws (M5×20) , fuel tank cap, and engine housing.
- Remove the fuel tube, fuel strainer and remove the fuel tank.
- Clean the fuel tank and dry it thoroughly.
- Install the strainer on fuel tank after cleaning and connect the fuel tube on.
- Check the fuel tank for leak.
- Install the engine housing, fuel tank cap and screws (M5×20) .

● Notice:

- Check fuel tank cover vent for blocked;
- Check the fuel strainer for clogged or broken;
- Check the fuel hose for aging an cracks;

4-3-3 Ignition coil/flywheel

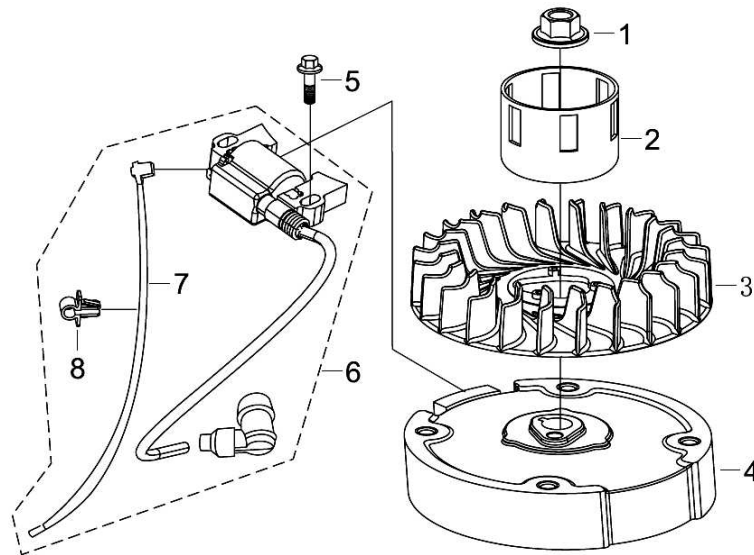

Ser. No.	Description	Ser. No.	Description
1	Flywheel nut	5	Hex. Flange bolt-big series -B class (M6×25)
2	Starting cup	6	Ignition coil
3	Impeller	7	Ignition coil stop wire
4	Flywheel assy.	8	Clip

● Ignition coil

NOTICE:

Check high tension line insulator for cracked, replace if necessary.

Assembly:

① Disassemble engine housing, fuel tank and recoil starter in order.

② Measure the clearance between the ignition coil and flywheel with the feeler.

③ Adjust the gap between the ignition coil and flywheel.

④ Adjust method: Loosen the bolt, move ignition coil radial along with flywheel to adjust gap with feeler and screw down the bolt.

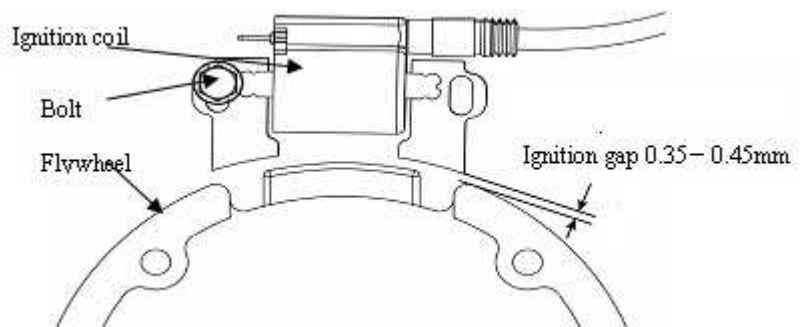

Check the ignition coil

(primary side)

Measure the resistance of the primary coil by attaching one ohmmeter lead to the ignition coil's primary terminal while touching the other tester lead to the iron core. Primary side resistance value: 1.0 -1.5Ω

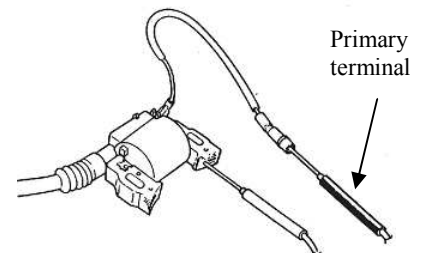

(Secondary side)

Measure the resistance of the secondary side of the coil with the spark plug cap removed, touching one test lead to the high tension cord while touching the other tester lead to the coil's iron core.

Secondary side resistance value: 5-7 k Ω

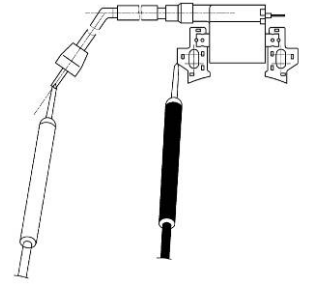

● Flywheel

Disassembly:

- ① Holding the flywheel with a commercially available flywheel brake, remove the nut (M14)
- ② Disassemble the starter cup and impeller.
- ③ Remove with a commercially available flywheel puller.

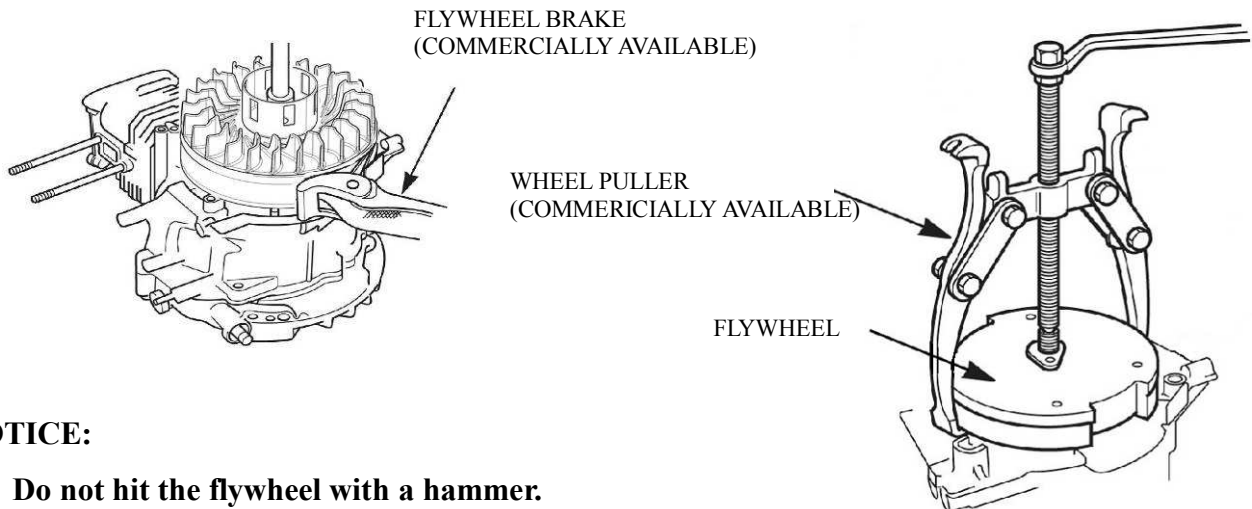

NOTICE:

- **Do not hit the flywheel with a hammer.**
- **Avoid the magnet section when attaching the puller.**

Assembly:

- a) Clean the tapered part of dirt on crankshaft and flywheel, oil grease and other foreign material before installation. Be sure that there is no washer and other foreign material on the magnetic part.
- b) Set the key in the key groove on the crankshaft.
- c) Install the flywheel over the crankshaft.

NOTICE: The flywheel may push the key out of its slot, check after assembling.

• **Flywheel nut torque value: 64 \pm 4N.m (aluminum flywheel) 78 \pm 4N.m (iron flywheel)**
Flywheel (cast iron)

- Attach by aligning the four small holes in the flywheel.
- Attach by aligning the lug on the rear side of the starter cup with the small hole at the center of the flywheel.

FLYWHEEL (CAST IRON)

IMPELLER

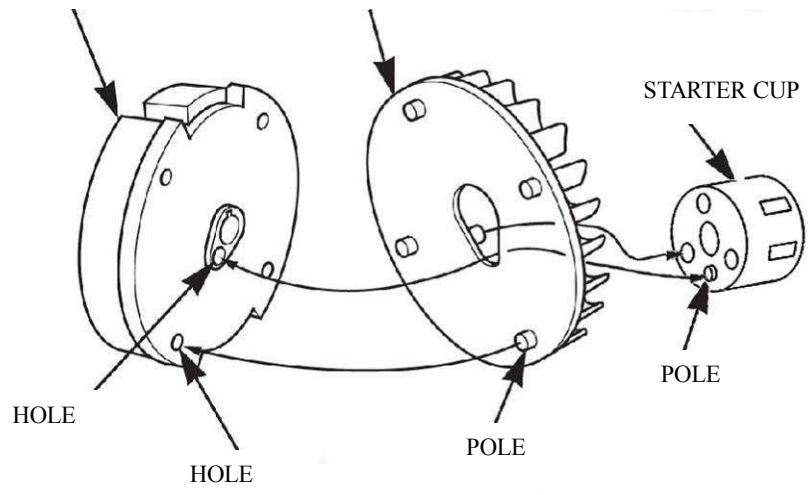

Flywheel (aluminum)

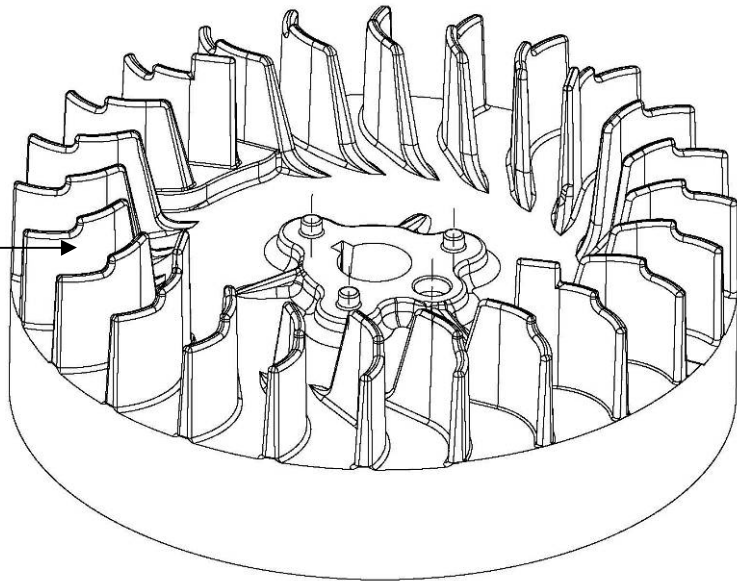

4-3-4 Muffler

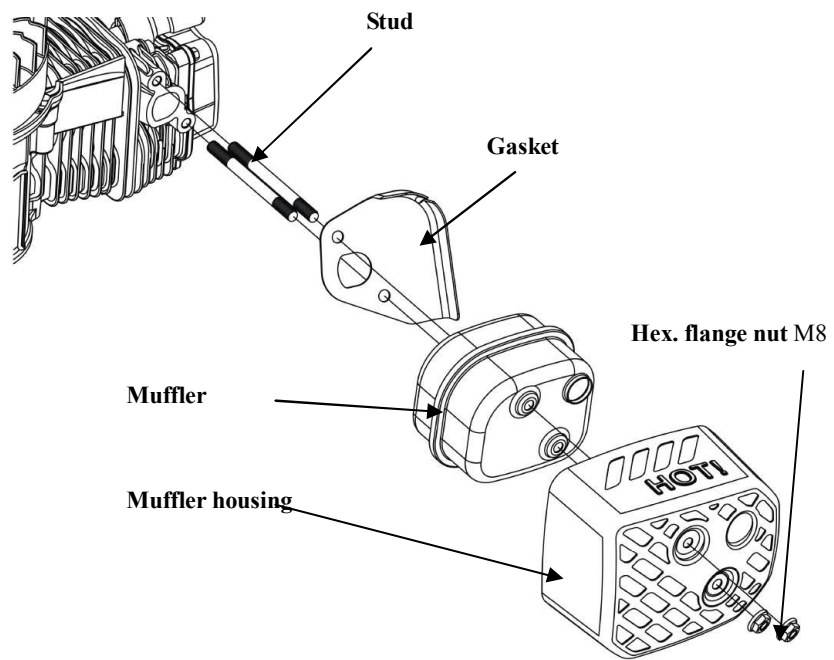

Disassembly/reassembly:

The muffler can produce carbon deposits in the long time operation and seriously trouble the exhaust system. To get the best performance, the muffler must be periodically removed the carbon deposits.

Lightly tap the muffler and blow it with compressed air in cleaning carbon deposits.

Replace it if the muffler exist in water and is seriously rusted to make noise increasing.

NOTICE: Don't clean with iron wire or the muffler material out to lower the muffler performance. Don't reuse the muffler gasket.

WARNING:

- **The muffler can glow heat. Please place the gasoline engine out touch of the passerby and children.**
- Don't place the flammable materials near the exhaust vent during operation.
- Don't stand on the exhaust port direction when engine is operating because the exhausted gas will be poisonous for your health.

4-3-5 Air cleaner

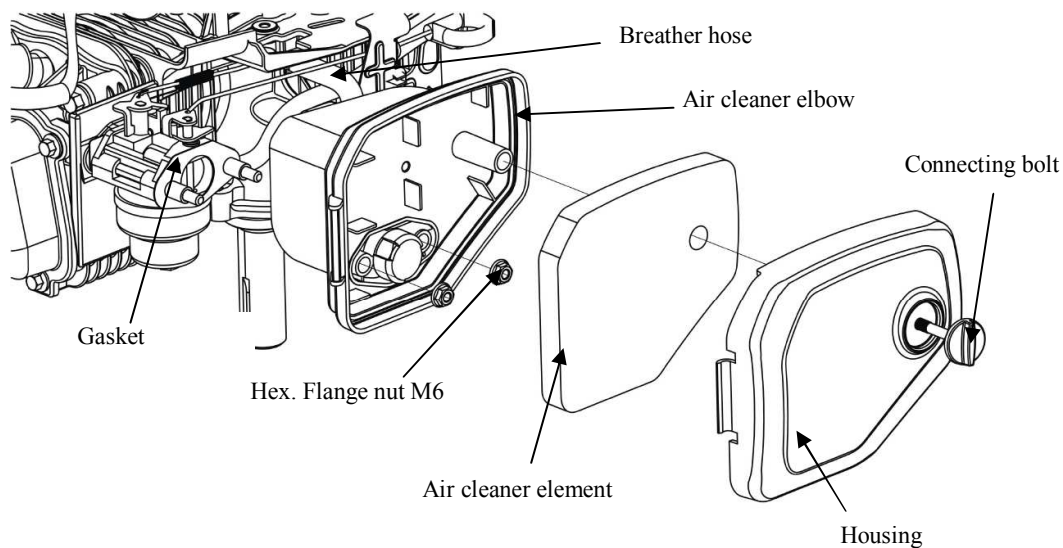

Disassembly/assembly:

Disassemble the air cleaner as shown on the above figure.

NOTICE

- Check for damage of the air cleaner gasket before reassembling. If necessary, please replace and pay attention to assembling direction, viewing from the air cleaner side.
- Before assembling, check breather hose for deterioration or damage. Replace if necessary. Pay attention to connect the beveled end shorter (big head end) to the air cleaner housing while the other end connect to the engine.

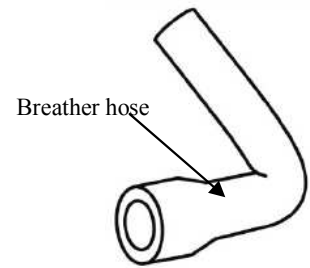

NOTICE:

- **Don't wash the foam element with the gasoline, acidity, alkalic or organic solvent**
- **Don't pull and wrest the sponge or it will be damaged.**

WARNING: Don't start the engine without air cleaner or the engine will be quickly worn.

4-3-6 Carburetor

NOTICE

At high altitude, the standard carburetor air-fuel mixture will be excessively rich. Output power will decrease, and fuel consumption will increase.

Engine performance can be improved by installing a smaller diameter main jet in the carburetor and readjusting the pilot screw. If you always operate the engine at altitudes higher than sea level 1000 meters over, have RATO authorized dealer perform this carburetor modification. If not, should lower load power in operating gasoline engine.

Even equipped with suitable carburetor, engine horsepower will decrease approximately 3.5% for each 300 meter increase in altitude. The effect of altitude on horsepower will be lowered greater than this if no carburetor modification is made.

If a carburetor suitable to high altitude is equipped with engine suitable to a lower altitude, the lean air fuel mixture will make engine output power lowering, over-heat and seriously damage.

The gasoline enters into the carburetor from the fuel tank and fuel filter. The fuel filter can filter the foreign matters in the gasoline and oxide out of the fuel tank. If having quality defectiveness, partly foreign matters will enter into the carburetor. Otherwise, the gasoline contains some composition which can form the colloid after long sediment, and attach in the carburetor parts

(such as main jet) fuel path and float chamber surface. The air enters into the carburetor through air filter. Considering the intake can not be too much resistant and other factors, the filter can not be too dense and therefore part of the air in the tiny impurities will enter into the carburetor through the air cleaner.

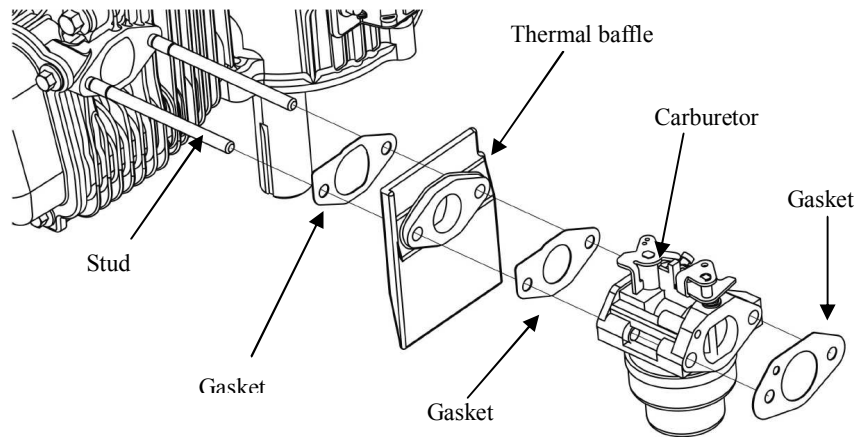

Disassembly/reassembly:

First disassemble air cleaner, and disassemble the carburetor as shown on the above figure.

NOTICE

·Before reassembling, check the carburetor thermal gasket, carburetor gasket, and air cleaner gasket for damaged, please replace it if necessary. Please pay attention to assembling direction.

● Carburetor

Wash the carburetor in the clean place, first, clean the outside surface, and wash the inside the parts with special carburetor detergent or gasoline. Except washing impurities, please wash the gasoline colloid on the part surface. Blow the washed parts clean with compression air, and don't use cloth and paper against recontaminating. Don't use the steel wire and other hard material to open the blocked hole to prevent carburetor performance from changing holes diameter. Use the gasoline and compression air to clean it.

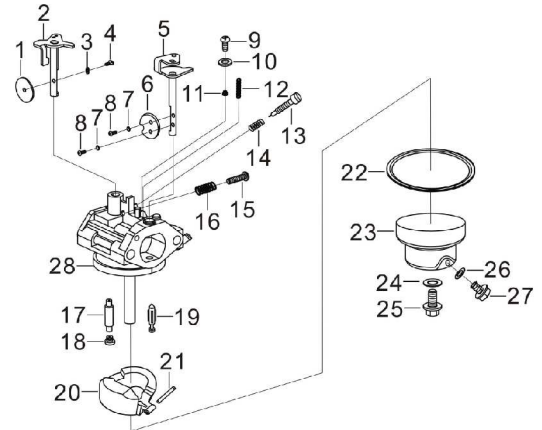

Ser.no.	Description	Ser.no.	Description	Ser.no	Description
1	Throttle valve	11	Pilot jet	21	Float pin
2	Throttle valve shaft	12	Choke stopper spring	22	Float chamber sealing ring
3	Small washer-A class	13	Pilot screw	23	Float chamber
4	Philips screw	14	Pilot screw spring	24	Sealing ring
5	Choke shaft	15	Throttle stop screw	25	Oil cup bolt
6	Choke	16	Screw spring (option)	26	Washer
7	Small washer-A class	17	Main nozzle	27	Oil drain plug
8	Philips screw	18	Main jet		
9	Philips screw	19	Needle valve		
10	Gasket	20	Float		

NOTICE:

- Loosen the drain bolt and completely drain the fuel out before installing carburetor.
- No fire

Reassembly:

(1) Check the float valve, float seat and float spring for wear.

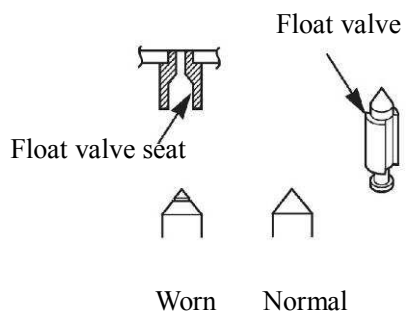

(2) Clean with compressed air before reassembling

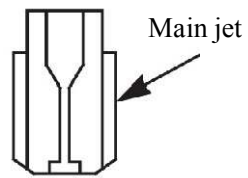

(3) Clean with compressed air before reassembling

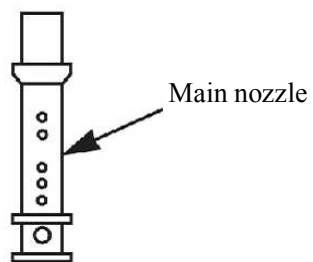

4-3-7 Throttle control

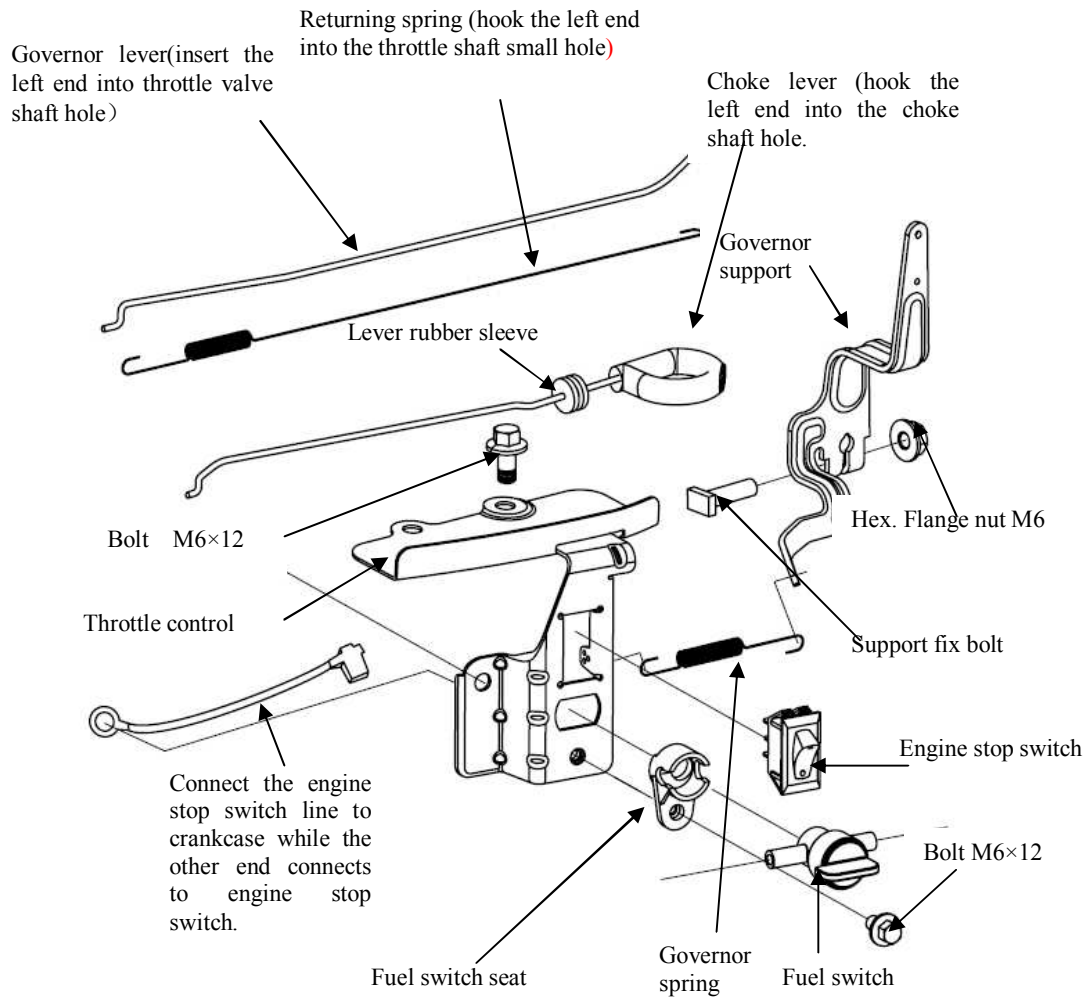

NOTICE

·Don't randomly replace throttle valve returning spring, and governor spring hooking position or result in performance of the engine unstable.

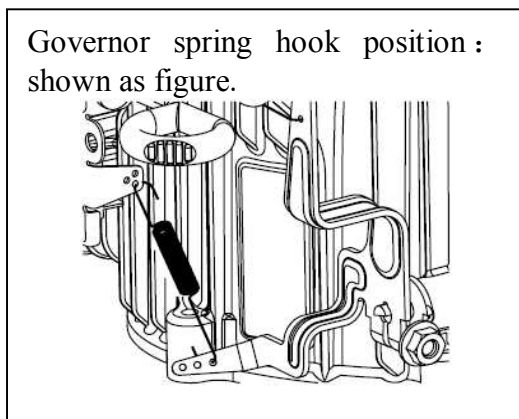

4-3-8 Cylinder head/valve train

Spark plug: Clean and adjust spark plug before installation

Cylinder head : Before installation, remove any carbon deposits from the combustion chamber, check retainer contact

Exhaust valve Before installation, remove carbon deposits and inspect the valve.

Dowel —A type (Φ10×14)

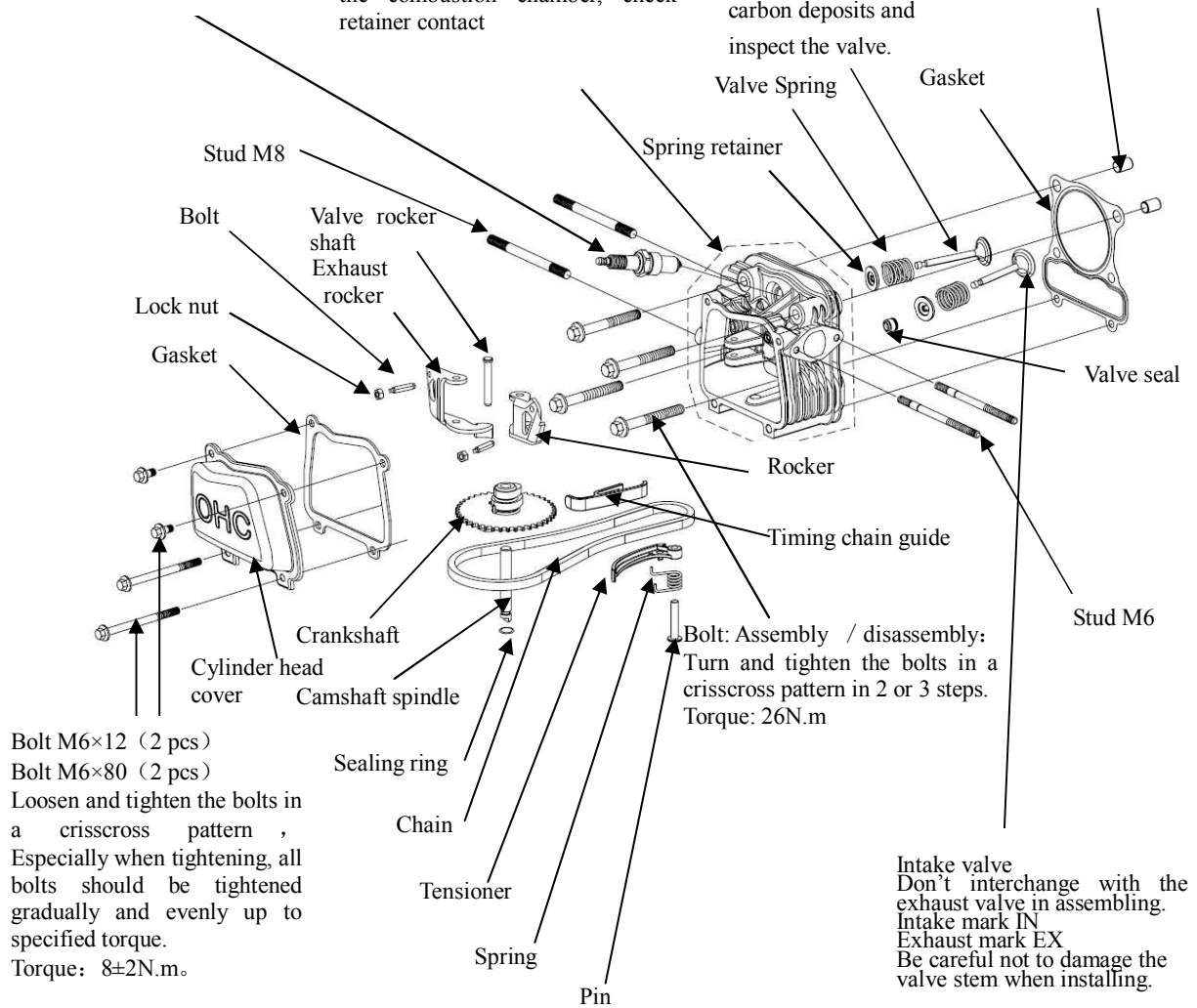

1) Disassembly/reassembly:

- | | |
|--|---------------------------|
| ① Disassemble recoil starter/housing; | ② Disassemble fuel tank; |
| ③ Disassemble ignition coil, flywheel; | ④ Disassemble muffler; |
| ⑤ Disassemble air cleaner; | ⑥ Disassemble carburetor; |

Finally, disassemble the cylinder head/valve train as shown on the above figure.

NOTICE:

Valve spring retainer:

Push down the valve spring and move the retainer to the side so that valve stem slips through the side hole.

Do not remove the valve spring retainers while the cylinder head is attached to the cylinder, or the valves will drop into the crankcase.

2) Inspect/ Service/ Repair:

① Valve stem outside diameter

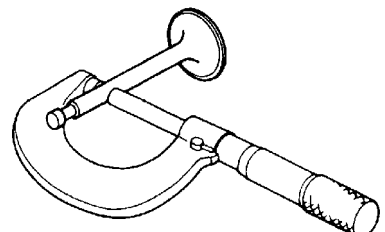
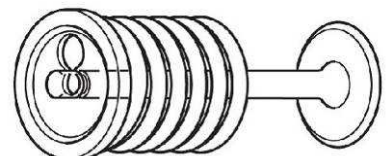

Inspect the valve stem outside diameter with the micrometer,

if finding out of the standard or service limit, or if visually inspecting the burn and damaged on the valve face, please replace with new one.

	IN	EX
Standard	5.440-5.455mm	5.430-5.445mm
<service limit>	5.310mm	5.300mm

② Valve spring free length

Measure the free length of the valve springs. If out of the standard or service limit. Please replace the spring

Standard	Service limit
30.5mm	28.5mm

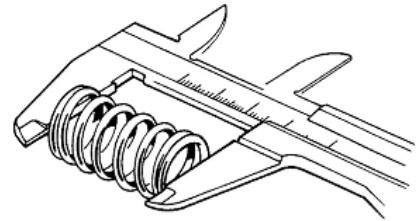

③ Valve Guide

Inspection:

a) Inspect the valve guide for smooth, scratch and damaged in the inner surface, and matching between the valve guide and the valve seat for fastness.

b) Using the valve guide reamer clean the valve guides to remove any carbon deposits before measuring.

If the valve guide inside diameter is below standard or out of the service limit, replace the guide.

Standard	Service limit
5.500-5.520mm	5.590mm

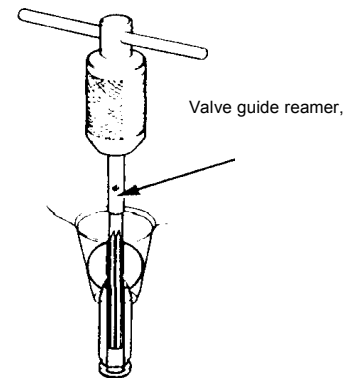

Replacement:

a) Chill the replacement valve guides in the freezer section of a refrigerator for about an hour.

b) Drive the valve guide out of the combustion chamber side using valve guide driver.

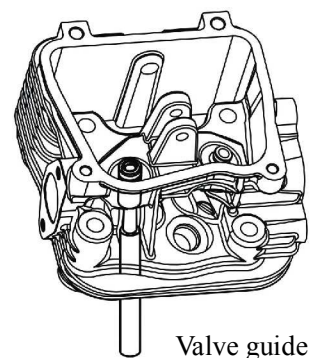

NOTICE: Be careful to avoid damaging the cylinder head when driving out the valve guides.

c) Install the new valve guides from the valve spring side of the cylinder head.

- Exhaust side: Drive the exhaust valve guide until the clip is fully seated (as shown as fig.)

- Intake side: Drive the intake valve guide to the specified height (measured from the top of the valve guide to the cylinder cover as shown as fig.)

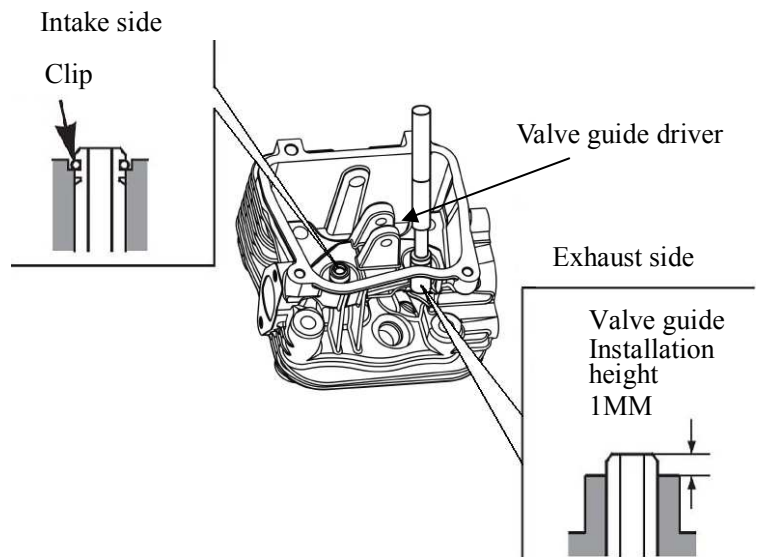

d) After installation, inspect the valve guide for damage, if damaged, please replace.

Reamer:

For best results, be sure the cylinder head is at room temperature before reaming valve guides.

Coat the reamer and valve guide with cutting oil. Rotate the reamer clockwise through the valve guide for the full length of the reamer. Continue to rotate the reamer clockwise while removing it from the valve guide.

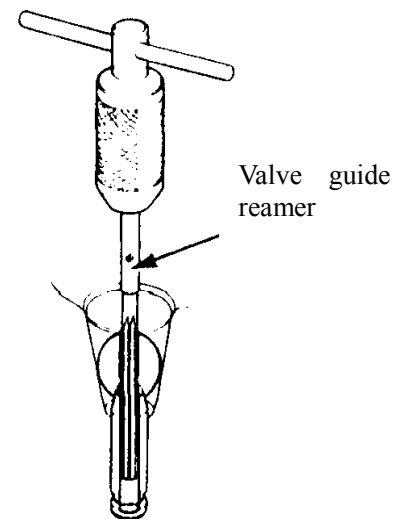

Tools: Valve guide reamer

a) Thoroughly clean the cylinder head to remove any cutting residue.

b) Check the valve guide bore, it should be straight, round and centered in the valve guide, insert the valve and check operation. If the valve does not operate smoothly, the guide may have been bent during installation. Replace the valve guide if it is bent or damaged.

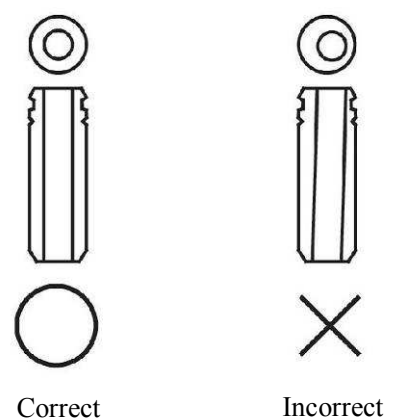

c) Check the valve stem-to-guide clearance

d) The valve stem-to-guide clearance: The valve guide bore deduct the valve stem outside diameter to get the clearance between the valve guide and valve stem.

e) If the clearance is over the service limit, judge a new guide if it can make the clearance conforming to service limit, if conforming to, replace the guide and ream the guide, refinish the valve when replacing the valve guide.

④ Valve seat:

a) Thoroughly clean the combustion chambers and valve seats to remove carbon deposits.

Apply a light coat of red lead powder or erasable color painting to the valve faces.

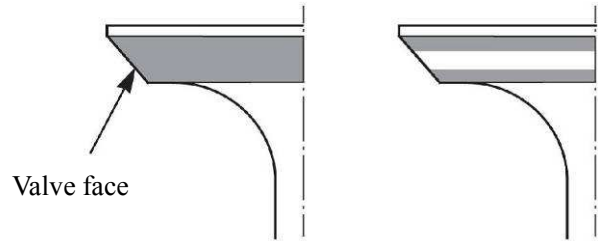

b) Insert the valves, and then press the valve several times forcefully. Be sure not to rotate valve on the seat. Valve seat painted the color will show contacted with the valve. If not, the transferred marking compound will show any area of the seat that is not concentric.

c) Using 45°cutter, remove enough material to produce a smooth and concentric seat. Turn cutter clockwise, never counterclockwise.

Tool: Valve seat cutter

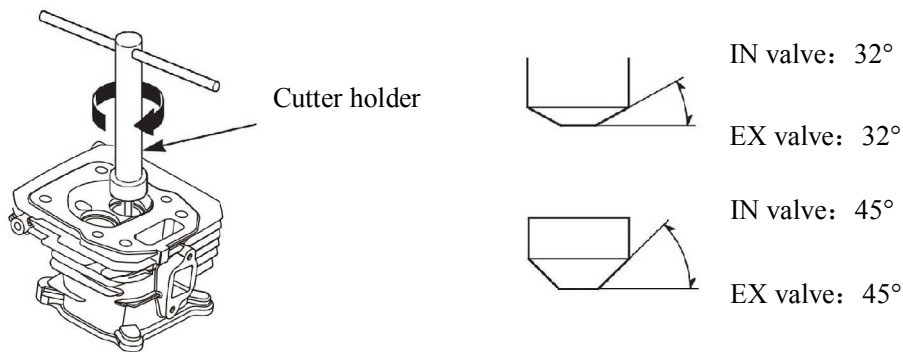

d) Use the 32°-45°cutters to narrow and adjust the valve seat so that it contacts the middle of the valve face.

. The 32°cutter removes material from the top edge (contact too high).

. The 45°cutter removes material from the bottom edge (contact too low). Be sure that the width of the finished valve seat is within specification.

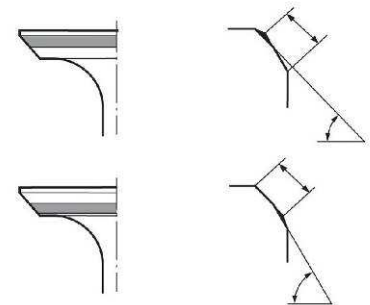

Standard	Service limit
0.8mm	2.0mm

e) Use 45°cutter to remove any possible burrs at the edges of the seat.

f) After resurfacing seat, inspect for even valve seating width. Apply colorant to the valve tapered face, insert the valve and press it forcefully several times, be sure the valve does not rotate on the seat. The seating surface, as shown by the transferred marking compound, should have good contact all the way around.

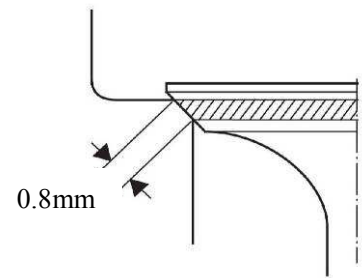

g) Apply the abrasives to the valve seat face, suitable for running in when rotating valve seat with valve seat cutter.

h) After reassembling, check the valve clearance

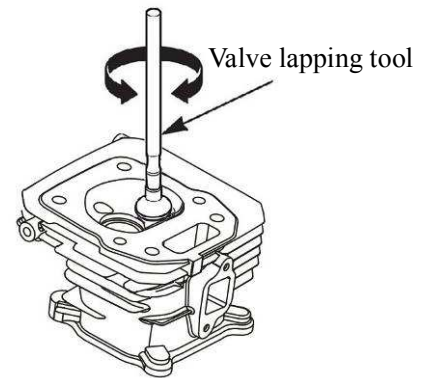

4-3-9 Crankcase cover/governor gear

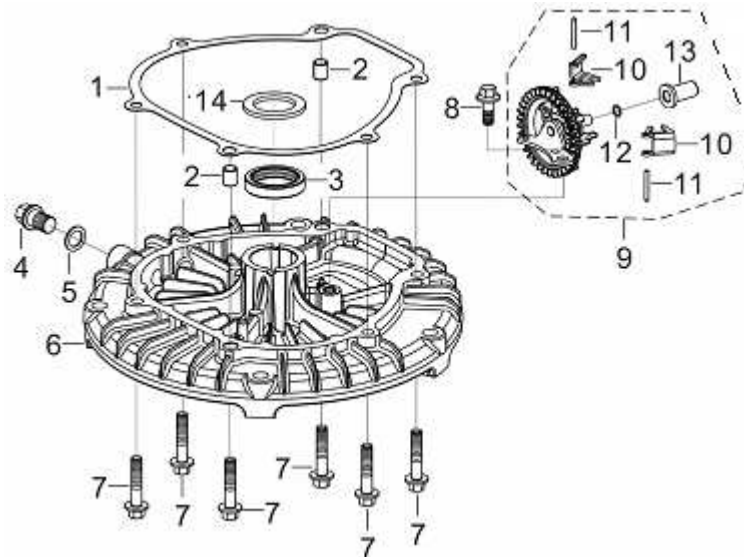

No.	Description	No.	Description
1	Gasket	8	Bolt (M6×16)
2	Dowel-A type	9	Governor gear Assy.
3	Oil seal $\Phi 27 \times \Phi 42 \times 7$	10	Governor flyweight
4	Drain plug	11	Flyweight spindle
5	Washer ($\Phi 10 \times \Phi 15.8 \times 1.5$)	12	Spindle clip
6	Crankcase cover	13	Governor slide
7	Bolt (M6×30)	14	Washer ($\Phi 37 \times \Phi 27.4 \times 1$)

NOTICE

- Don't reuse the crankcase gasket.
- Oil seal: a) Don't reuse; b) Apply the lubrication oil on the lip when using; c) Put the oil seal into the crankcase cover with special tool, don't damage the edge of the oil seal; d) Apply the special lubrication oil onto oil seal after assembling.
- Don't reuse the oil drain plug washer, as can as possible use new one.
- Bolt (M6×30): Loosen and tighten the bolts in a crisscross pattern, Especially when tightening, all bolts should be tightened gradually and evenly up to specified torque. Bolt torque: $10 \pm 2 \text{N.m}$.
- Governor gear: First, check governor gear for worn and damaged, then, assemble it.
- Governor spindle clip: Firmly insert governor spindle clip into the groove of the shaft when assembling.
- Governor slider: Insert the governor slider into the governor spindle and check the governor slider for turning freely.

4-4-10 Crankshaft/piston/crankcase

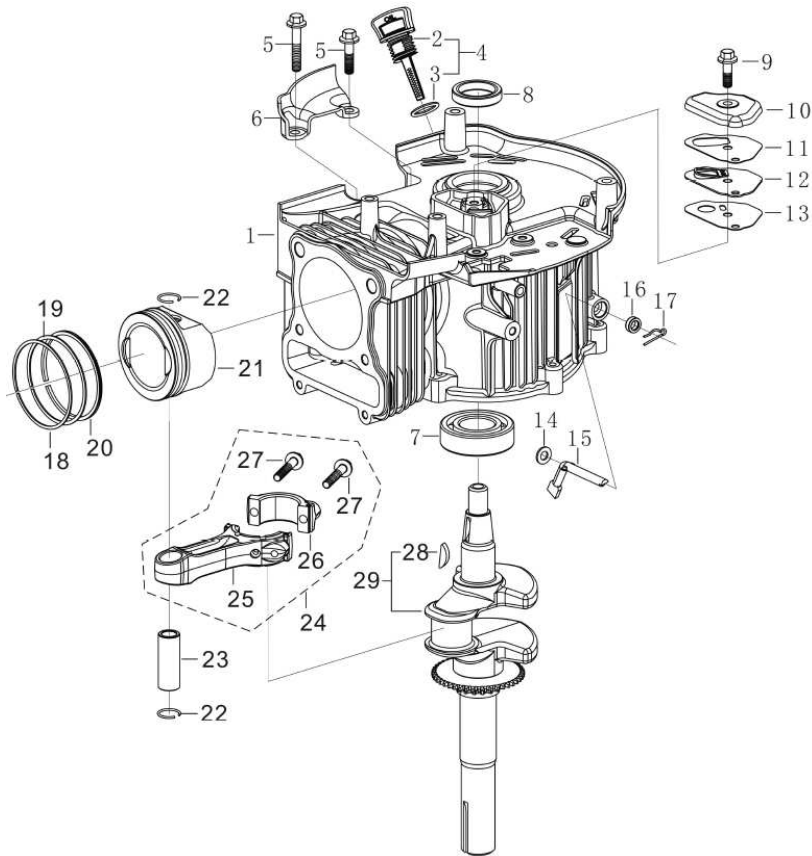

No.	Description	No.	Description	No.	Description
1	Crankcase assy.	11	Gasket	21	Piston
2	Oil dipstick	12	Breath piece assy.	22	Clip
3	Seal ring	13	Gasket	23	Pin
4	Oil dipstick	14	Flat washer-A class	24	Connecting rod
5	Bolt (M6×16)	15	Governor arm	25	Connecting rod body
6	Lower cover	16	Oil sealΦ6×Φ11×4	26	Connecting rod cover
7	Ball bearing	17	Split pin	27	Connecting rod bolt
8	Oil sealΦ25×Φ35×6	18	First ring	28	Woodruff key
9	Bolt (M6×20)	19	Second ring	29	Crankshaft
10	Breather cover	20	Oil ring assy.	30	

Disassembly/reassembly:

① Reassembly:

a) Piston

- Install with the maker mark facing upward as shown.
- Do not interchange the top ring and the second ring (top ring with chrome plated)
- After assembly, check for smooth movement of the piston ring.
- Stagger the piston ring end gaps 120° apart.

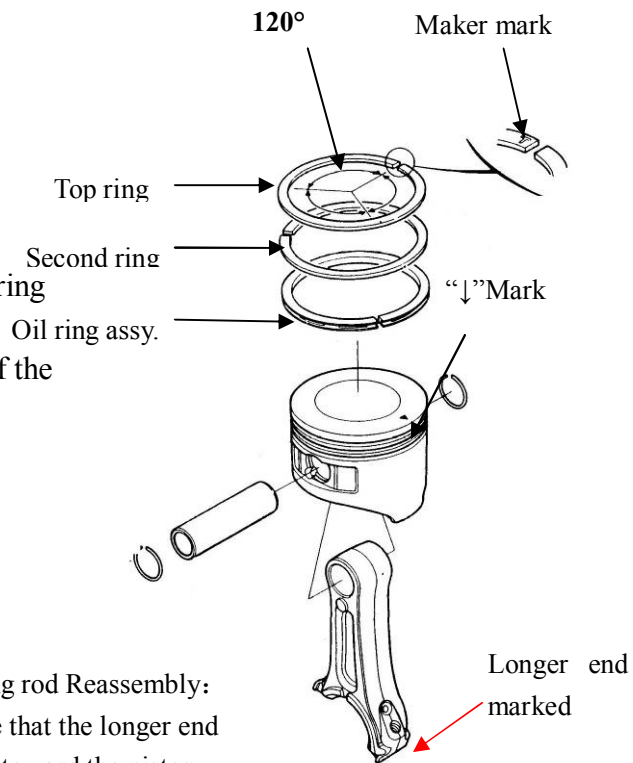

Connecting rod Reassembly:
Make sure that the longer end marked is toward the piston head with the “↓”

b) Piston pin clip

Install by setting front end of the clip in the piston groove, holding the other end with long nosed pliers, and rotating the clip in.

Do not align the end gap of the clip with the cut out in the piston pin bore.

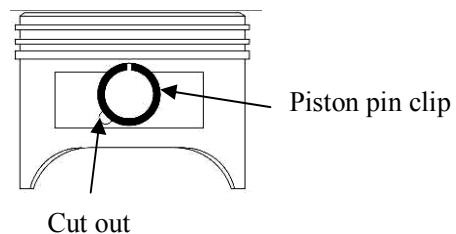

c) Connecting rod cap

Install by aligning the alignment marks on the connecting rod cap. Connecting rod bolt: Torque value: $13 \pm 1 \text{ N.m}$

Alignment marks

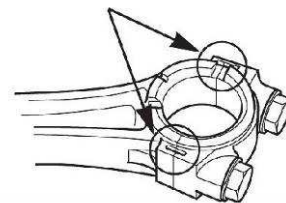

d) Bearing

- Apply oil to the circumference of a new ball bearing.
- Drive the ball bearing in the cylinder barrel using special tool.

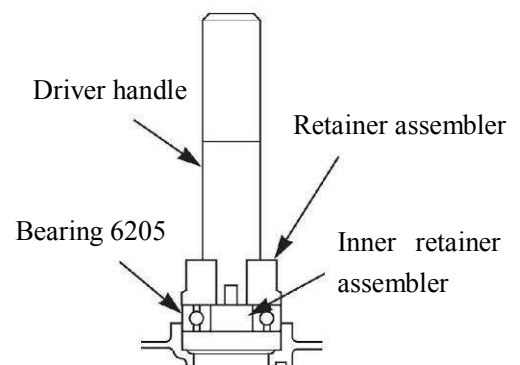

Tools: Driver handle, Retainer assembler, Inner assembler

e) Oil seal:

- Apply oil to the circumference of an oil seal.
- Drive the oil seal in the cylinder barrel using following tool.

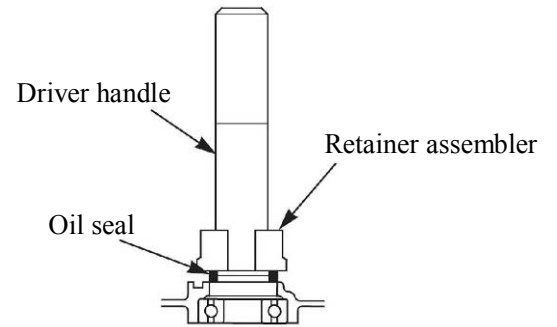

Tools: Driver handle, Retainer assembler

- Apply the lubrication oil on, after reassembling.

f) Piston:

- Apply oil to the piston and cylinder
- **Install the piston with the mark on the piston head opposite to the chain hole side.**

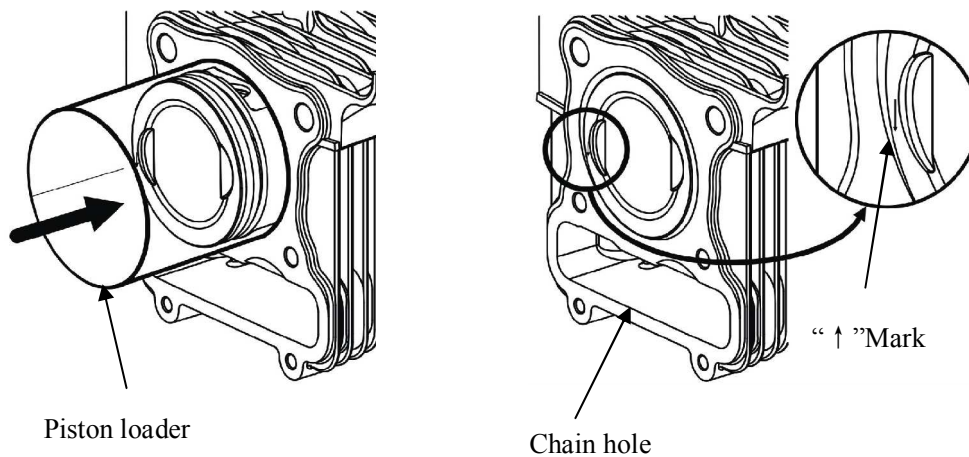

②Piston check

Check the piston and cylinder for contacting, and check the groove for fault, piston top for burn and cracks. If damaged, replace.

Clean the carbon deposit

Clean the deposit round the piston top and cylinder neck before checking, first soak the carbon deposit with kerosene, and then clean with meter scraper or metal brush.

Piston skirt O.D.

Measure the piston skirt O.D. with outside micrometer, if out of the service limit, replace it.

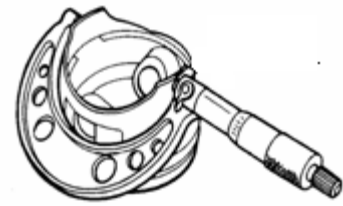

Standard	Service limit
67.971-67.989mm	67.850mm

b) Piston pin bore to piston clearance

Separately measure the piston pin bore I.D and O.D. with inside micrometer and outside micrometer. Then calculate clearance by measuring results.

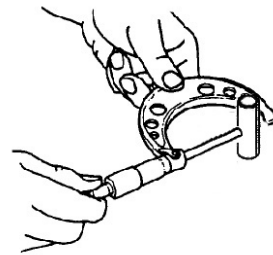
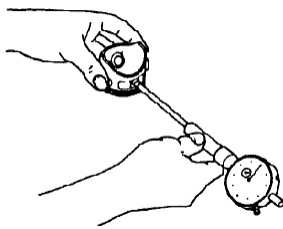

Standard	Service limit
0.006-0.018mm	0.060mm

c) Piston-cylinder clearance

Difference between the diameter of cylinder maximum and piston skirt should be considered as piston-cylinder clearance.

Check with piston converting in the cylinder, and inserting feeler between piston skirt bearing face and wall, then pull the feeler out, if feeling resistance and smoothly out, the thickness of the feeler shall be considered as piston-cylinder clearance.

Standard	Service limit
0.011-0.049mm	0.120mm

NOTICE: This clearance must be checked before and after repairing.

d) Piston ring side clearance

- . Check with placing each ring into each-self groove.
- . The piston ring should be freely turned without loosening and sticking.
- . Then measure with inserting feeler into clearance of the ring between groove upper and lower face.

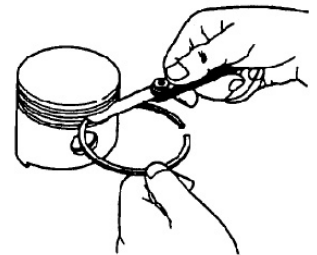

Standard (The first ring/second ring)	Service limit
0.04~0.08/0.04~0.08mm	0.150mm

e) Piston ring end gap

Flatly place the piston into the cylinder with pushing the piston head to working position. Measure the opening clearance with feeler, that clearance should not be too big or not too small, being too big can result in poor cylinder sealing performance while being too small can result in piston expansion from heating and cylinder block, thus causing piston broken and “sticking”. If opening clearance is too small, file the opening with fine flat file. Check in the cylinder often when filing until the proper clearance is got.

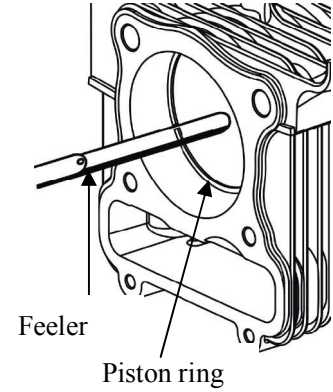

	Standard	Service limit
The first ring	0.13-0.28mm	1.0mm
The second ring	0.20-0.40mm	1.0mm

③ Check connecting rod

If connecting rod bending, twisting or big end shaft bush and small end outer ring movement or crack on one side, should be rejected and replaced with new one.

a) Check small end diameter

If out of the standard or exceed service limit, replace the connecting rod.

Standard	Service limit
16.005-16.021mm	16.090mm

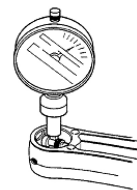

b) Check big end diameter

If out of the standard or exceed service limit, replace the connecting rod.

Standard	Service limit
30.000-30.018mm	30.066mm



c) Connecting rod big end oil clearance

- Wipe oil off the crank pin and connecting rod bearing mating surface.
- Set the plastic gauge on the crank pin, connecting rod and bolt to specified torque. Torque: $13 \pm 1 \text{ N.m}$

NOTICE: Place the plastic gauge axially.

- Remove connecting rod and measure with plastic gauge.
- If the clearance exceeds the service limit, replace the connecting rod and recheck the clearance.

Standard	Service limit
0.019-0.049mm	0.120mm

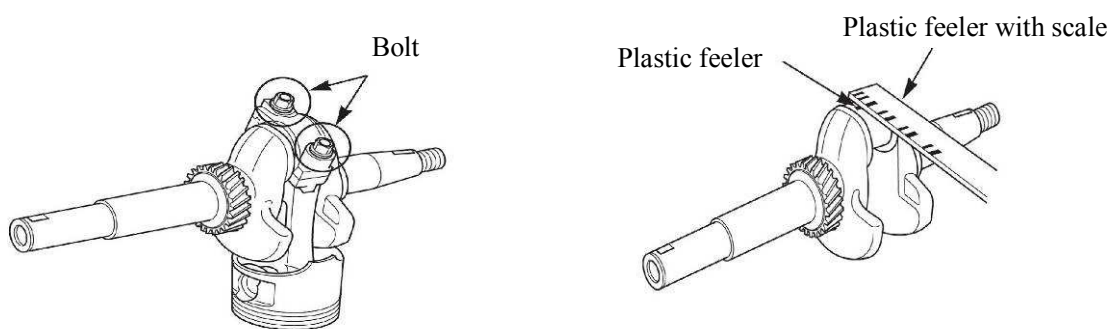

④ Camshaft check

The camshaft is main driving part of the train valve mechanism, which controls the intake and exhaust valves opening and closing.

Feature: The shaft is equipped with cam and journal which can control intake and exhaust. When operating, camshaft operating face and lifter will be badly rubbed from periodically impacting and easily be damaged. So, the camshaft shall be wearable and lubrication well.

- Visually inspect cams' surface and cams' height for damaged, and camshaft bore for loosening and wearing, replace as required.
- Check camshaft for height dimension. If out of the service limit, replace the camshaft.

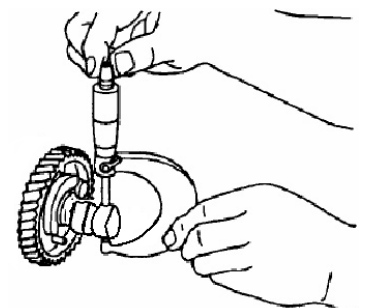

	Standard	Service limit
IN lifter	23.98mm	23.730mm
EX lifter	27.88 mm	27.630mm

· Check inner diameter of the camshaft bore, if bigger than the service limit, replace the camshaft.

Standard	Service limit
9.00-9.04mm	9.1090mm

If the sprocket teeth damaged, please replace the camshaft with new one.

Camshaft wearing cause analyses and to engine performance influence:

Poor lubrication will result in camshaft abnormal wearing, such as, oil viscosity low, impurity too much, and recycling oil little can't let the camshaft surface forming complete oil film to make the camshaft surface seriously worn in the high speed rubbing stat. Second, installing precision problem, when the matching clearance of the camshaft journal and camshaft seat or bearing is out of the service limit, camshaft rotation precision will lower and contacting with the relative part produce deviation face to make abnormal wearing.

⑤ Crankshaft: Push the bearing with care until it contacts the crankshaft in order not to damage the crankshaft output end and timing gear.

·Check timing gear for engagement clearance of the chain. The camshaft, timing chain guide, tensioner, and crankshaft timing gear should be sufficiently matched with chain and contact governor driven gear of the governor gear.

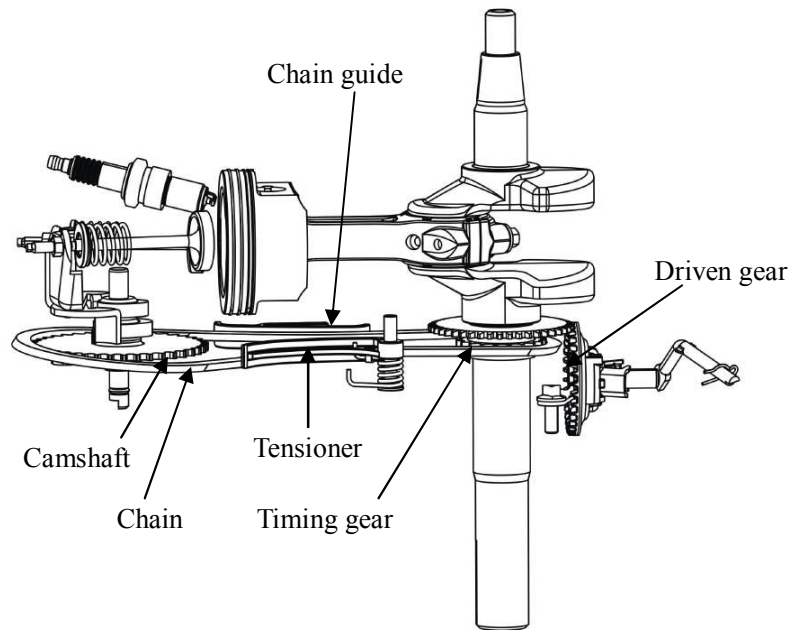

·Timing gear will be damaged in gear worn, gear face peeling off, and gear teeth broken. Due to gear wearing, the engagement clearance will become bigger, and the noise will become bigger.

·If the timing gear face is damaged, please replace with new one.

NOTICE: Please replace the gear with a new set to ensure the engaging face completely engage in.

4-5 Electric diagram

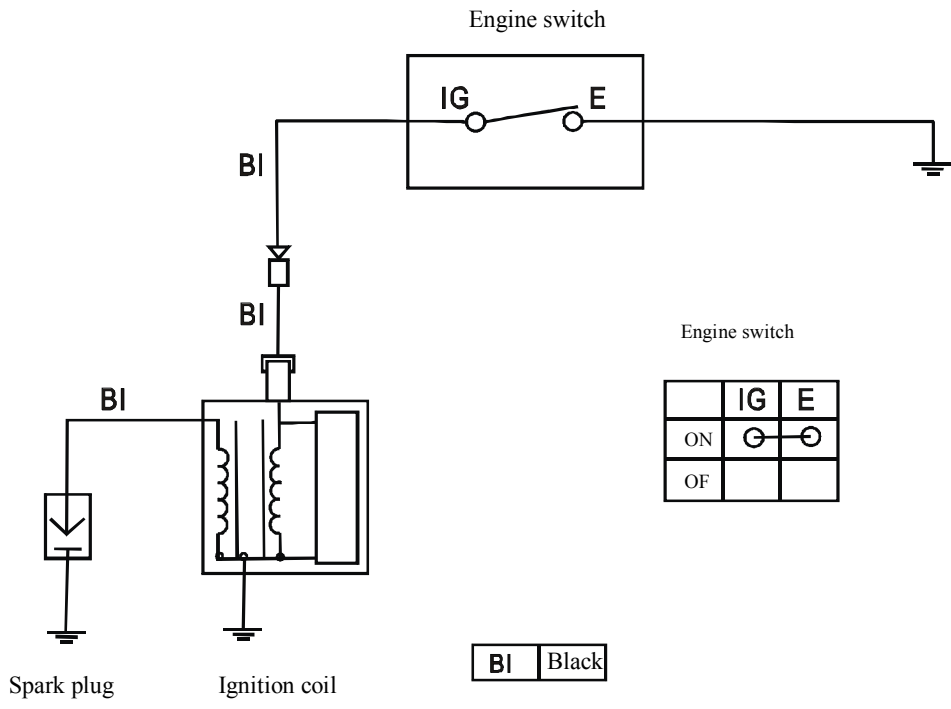

ISSUE EMD-ES7175



SUBARU
FUJI HEAVY INDUSTRIES LTD.
INDUSTRIAL PRODUCTS COMPANY
<http://www.subaru-robin.jp>

December 2010